

Scottish Health Technical Memorandum 03-01

Ventilation for healthcare premises Part A – Design and validation

Contents

	<i>page</i>
Acknowledgements	6
Preface	7
About Scottish Health Technical Memoranda	7
Structure of the Scottish Health Technical Memorandum suite	8
1. Introduction	10
1.8 Statutory requirements	10
1.22 Functional overview – Terms in use	13
1.35 Management action	16
1.39 Design and validation process	16
1.40 Use and function of typical equipment used in ventilation plant	18
2. Provision of ventilation in healthcare buildings	22
2.2 Natural ventilation	22
2.6 Extract ventilation systems	22
2.8 Supply only ventilation	23
2.9 Supply and extract ventilation	23
2.10 Mechanical or comfort cooling	23
2.15 Air-conditioning	24
2.17 Specialised ventilation	24
2.19 Ventilation for general areas	24
2.20 Use of natural ventilation	24
2.25 Mixed mode ventilation	25
2.27 Mechanical extract ventilation	25
2.32 Mechanical supply systems	25
2.34 Balanced ventilation	26
2.35 Cascade ventilation	26
2.36 Recirculation systems	26
2.38 Chilled beams	27
2.41 Split comfort air-conditioners	27
2.47 Dilution ventilation and clean air flow paths	27
2.50 Mechanical ventilation systems	28
2.55 Zoning of the building	29
2.60 Specific requirements for hospital departments	30

3.	Assessment of service requirement.....	31
3.1	Selection of design criteria	31
3.25	Calculation of building loads.....	34
3.46	Calculation of plant requirements	36
3.58	Provision of primary services.....	38
3.61	Inlet and discharge sizing and location.....	39
3.72	Heat rejection devices	40
4.	Air handling unit design and specification guidance	41
4.1	General requirements.....	41
4.37	Fans	45
4.64	Heater batteries / heater coils.....	49
4.78	Cooling coils	50
4.91	Humidifiers	52
4.115	Filtration.....	54
4.142	Energy-recovery.....	58
4.151	Attenuation	59
5.	Air distribution system	62
5.1	Air distribution arrangements.....	62
5.17	Fire aspects, damper types and locations	64
5.22	Duct sections	64
5.39	Thermal insulation	66
5.56	Diffuser and grille selection and sizing	68
5.75	Pressure stabilisers - size and location	70
6.	Automatic controls.....	72
6.2	General requirements.....	72
6.7	Objectives of control system.....	72
6.12	Location of controls	73
6.17	Fire aspects.....	74
6.20	Time switching.....	74
6.22	Start-up control.....	75
6.23	Set-back control	79
6.24	Use control	79
6.27	Environmental control.....	79
7.	Specialised ventilation systems	83
7.5	General information.....	84
7.32	7.0 (a) Operating department ventilation systems	88

7.79	Ventilation of operating department ancillary areas.....	96
7.88	7.0 (b) Ultra-clean ventilation systems	97
7.100	Types of UCV system.....	99
7.140	7.0 (c) Extract systems	106
7.146	Hood extract systems	108
7.154	Bench extract systems	109
7.182	7.0(d) Plantroom ventilation.....	112
7.204	7.0(e) Ventilation of hydrotherapy suites	114
8.	Validation of specialised ventilation systems	116
	Definitions.....	116
8.1	Commissioning general	116
8.3	Location of dampers and test holes.....	117
8.8	Information to be provided.....	117
8.9	Commissioning personnel	118
8.12	Commissioning brief.....	119
8.18	Pre-commissioning checks.....	120
8.19	Standard of installation	120
8.20	Cleanliness of installation	121
8.24	Certification of equipment.....	121
8.25	Equipment tests.....	122
8.26	Filters	122
8.27	Drainage arrangements.....	122
8.28	Fire dampers	123
8.29	Dynamic commissioning.....	123
8.43	Specific performance standards	124
8.52	Filter challenge	125
8.59	Bacteriological sampling.....	126
8.64	Ventilation system commissioning/validation report	127
8.66	8.0(a) Validation of UCV operating suites	127
8.101	Vertical UCV terminal air velocity tests.....	132
8.117	Horizontal UCV terminal air velocity test	133
8.129	UCV entrainment test (Vertical systems only)	134
8.156	UCV visualisation	138
8.157	UCV noise level.....	138
8.163	UCV control system checks.....	139
8.170	UCV theatre microbiological tests	140
8.173	UCV validation report	140
	Appendix 1: Table A1: Recommended air-change rates	141

Appendix 2: Hierarchy of cleanliness	143
Appendix 3: Operating suite design logic	147
Appendix 4: Design of air-movement control schemes for operating theatres.	156
References.....	182
Acts and regulations	182
British Standards	182
Department of Health Publications	183
NHSScotland Publications.....	183
Chartered Institution of Building Services Engineers publications.....	184
Heating & Ventilating Contractors’ Association (HVCA) publications ...	184
Other publications	185

Disclaimer

The contents of this document are provided by way of general guidance only at the time of its publication. Any party making any use thereof or placing any reliance thereon shall do so only upon exercise of that party’s own judgement as to the adequacy of the contents in the particular circumstances of its use and application. No warranty is given as to the accuracy, relevance or completeness of the contents of this document and Health Facilities Scotland, a Division of NHS National Services Scotland, shall have no responsibility for any errors in or omissions therefrom, or any use made of, or reliance placed upon, any of the contents of this document.

Acknowledgements

Health Facilities Scotland would like to thank the principal contributors and the Steering Group led by the Department of Health for their efforts in producing the HTM 03-01 Part A document.

HTM 03-01 Part A has been updated and amended by Health Facilities Scotland for use in NHSScotland as SHTM 03-01 Part A and the contribution from the National Heating & Ventilation Advisory Group is gratefully acknowledged.

Preface

About Scottish Health Technical Memoranda

Engineering Scottish Health Technical Memoranda (SHTMs) give comprehensive advice and guidance on the design, installation and operation of specialised building and engineering technology used in the delivery of healthcare.

The focus of Scottish Health Technical Memorandum guidance remains on healthcare-specific elements of standards, policies and up-to-date established best practice. They are applicable to new and existing sites, and are for use at various stages during the whole building lifecycle.

Healthcare providers have a duty of care to ensure that appropriate engineering governance arrangements are in place and are managed effectively. The Engineering Scottish Health Technical Memorandum series provides best practice engineering standards and policy to enable management of this duty of care.

It is not the intention within this suite of documents to repeat unnecessarily international or European standards, industry standards or UK Government legislation. Where appropriate, these will be referenced.

Healthcare-specific technical engineering guidance is a vital tool in the safe and efficient operation of healthcare facilities. Scottish Health Technical Memorandum guidance is the main source of specific healthcare-related guidance for estates and facilities professionals.

The core suite of eight subject areas provides access to guidance which:

- is more streamlined and accessible;
- encapsulates the latest standards and best practice in healthcare engineering;
- provides a structured reference for healthcare engineering.

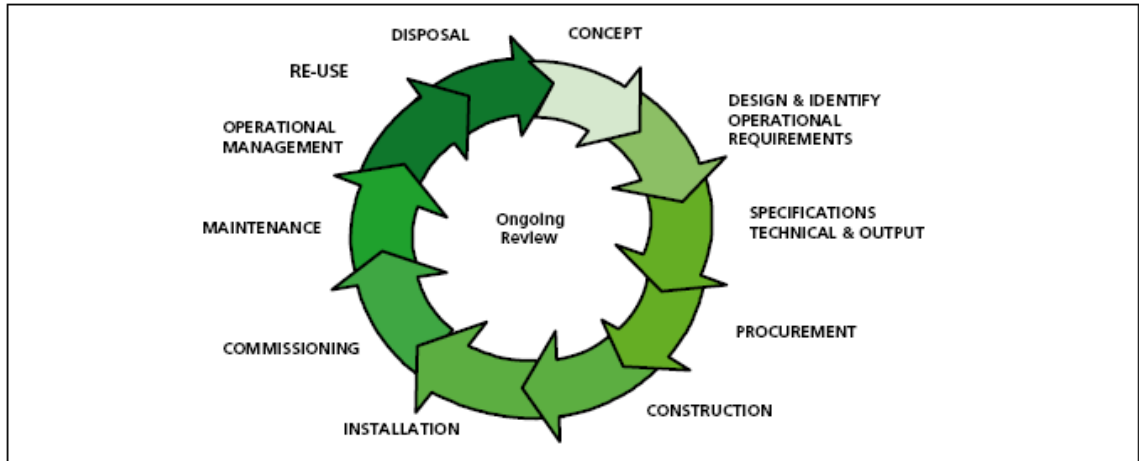

Healthcare building lifecycle

Structure of the Scottish Health Technical Memorandum suite

The series of engineering-specific guidance contains a suite of eight core subjects:

Scottish Health Technical Memorandum 00: Policies and principles (applicable to all Scottish Health Technical Memoranda in this series).

Scottish Health Technical Memorandum 01: Decontamination.

Scottish Health Technical Memorandum 02: Medical gases.

Scottish Health Technical Memorandum 03: Heating and ventilation systems.

Scottish Health Technical Memorandum 04: Water systems.

Scottish Health Technical Memorandum 05: Reserved for future use.

Scottish Health Technical Memorandum 06: Electrical services.

Scottish Health Technical Memorandum 07: Environment and sustainability.

Scottish Health Technical Memorandum 08: Specialist services.

Some subject areas may be further developed into topics shown as -01, -02 etc and further referenced into Parts A, B etc.

Example: Scottish Health Technical Memorandum 06-02 Part A will represent: Electrical Services – Electrical safety guidance for low voltage systems.

In a similar way Scottish Health Technical Memorandum 07-02 will simply represent:

Environment and Sustainability – EnCO₂de.

All Scottish Health Technical Memoranda are supported by the initial document Scottish Health Technical Memorandum 00 which embraces the management and operational policies from previous documents and explores risk management issues.

Some variation in style and structure is reflected by the topic and approach of the different review working groups.

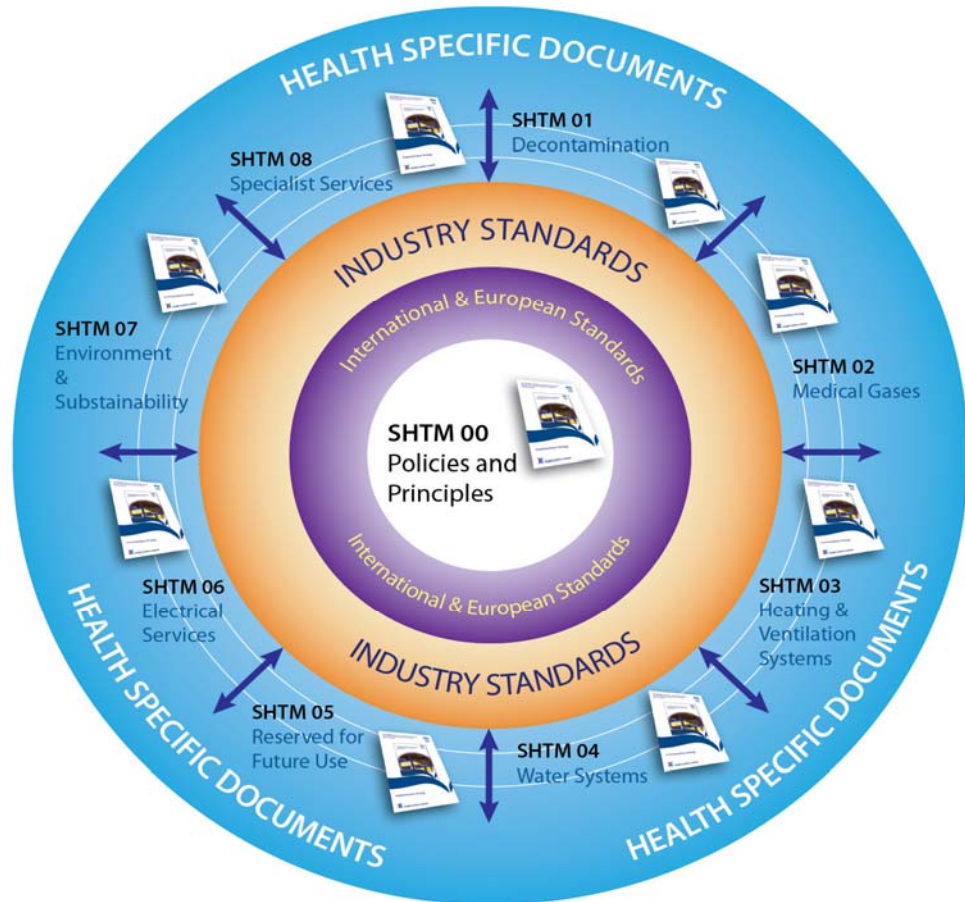

Engineering guidance

1. Introduction

- 1.1 Ventilation is used extensively in healthcare premises for primary patient treatment in operating departments, high dependency units and isolation facilities. It is also installed to ensure compliance with quality assurance of processed items in pharmacy and sterile supply departments and to protect staff from harmful organisms and toxic substances, for example, in laboratories.
- 1.2 This edition of Scottish Health Technical Memorandum 03 'Ventilation in healthcare premises' is published in two sections. It is equally applicable to both new and existing sites. It gives comprehensive advice and guidance to healthcare management, design engineers, estate managers and operations managers on the legal requirements, design implications, maintenance and operation of general and specialised ventilation in all types of healthcare premises.
- 1.3 Current statutory legislation requires both 'management' and 'staff' to be aware of their collective responsibility.
- 1.4 'Ventilation' is also provided in healthcare premises for the comfort of the occupants of buildings. More specialised ventilation will also provide comfort but its prime function will be to control closely the environment and air movement of the space that it serves in order to contain, control and reduce hazards to patients and staff from airborne contaminants, dust and harmful micro-organisms.
- 1.5 Ventilation systems in themselves present little danger to patients or staff. However, they do possess the ability to transmit hazards arising from other sources to large numbers of people. The danger may not become apparent until many patients and staff have been affected.
- 1.6 The sophistication of ventilation systems in healthcare premises is increasing. Patients and staff have a right to expect that it will be designed, installed, operated and maintained to standards that will enable it to fulfil its desired functions reliably and safely.
- 1.7 The Health and Safety at Work etc Act 1974 (HSW Act 1974) is the core legislation that applies to ventilation installations. As these installations are intended to prevent contamination, control closely the environment, dilute contaminants or contain hazards. Their very presence indicates that risks to health have been identified.

Statutory requirements

- 1.8 The Control of Substances Hazardous to Health (COSHH) regulations place upon management an obligation to ensure that suitable measures are in place to protect their staff and others affected by the work activity. These methods may include both safe systems of work and the provision of a specialised

ventilation system. In laboratories the requirements are often met by the provision of fume cupboards and safety cabinets.

- 1.9 The existing requirements to provide ventilation, implicit under HSW Act 1974 and COSHH, have been made explicit by the Management of Health and Safety at Work Regulations 1999, the Workplace (Health, Safety and Welfare) Regulations 1992 and the Provision and Use of Work Equipment Regulations 1998, all issued as a result of European Directives.
- 1.10 Where specialised ventilation plant is provided as part of the protection measures there is a statutory requirement that it be correctly designed, installed, commissioned, operated and maintained. The local exhaust ventilation (LEV) section of the COSHH regulations requires that the plant be inspected and tested at least every 14 months by an independent organisation and that management maintain comprehensive records of its performance, repair and maintenance.
- 1.11 Certain substances have Occupational Exposure Limits (OEL) set out in Guidance Note EH 40 published annually by the Health and Safety Executive. If special ventilation systems are provided in order to achieve these standards they will be subject to the COSHH regulations as above.
- 1.12 All ventilation systems should conform to the principles set out in the Approved Code of Practice and guidance document entitled “Legionnaires’ disease: the control of *Legionella* bacteria in water systems” (commonly known as L8) published by the Health and Safety Executive and Scottish Health Technical Memorandum SHTM 04-01: The control of *Legionella*, hygiene, “safe” hot water, cold water and drinking water systems.
- 1.13 Special ventilation plants installed in laboratories dealing with research, development or testing, whether involving drugs, animals or genetically modified organisms, may be subject to particular legislation with regard to their operation in addition to that mentioned above. Further information is given by the Health and Safety Executive Health Services Advisory Committee in:
- safe working and prevention of infection in clinical laboratories;
 - safe working and prevention of infection in clinical laboratories: model rules for staff and visitors;
 - safe working and prevention of infection in clinical laboratories in the mortuary and post-mortem room.
- 1.14 Plants installed in units manufacturing medicinal products to the standards set out in the current European Guide to Good Manufacturing Practice may also be subject to particular legislation with regard to their operation in addition to that mentioned above.
- 1.15 Records should be kept of equipment design and commissioning information. The Health and Safety Executive, Medicines Inspectorate and other interested bodies have a statutory right to inspect them at any time. All records should be kept for at least five years.

- 1.16 The fire regulations require that if ventilation ductwork penetrates the fabric of a building it should be designed and installed so as to contain the spread of fire. (for further information refer to Firecode Series SHTMs 81, 83 and 85)
- 1.17 Increased health risks to patients will occur if the more specialised ventilation systems installed to supply high quality air to operating departments do not achieve and maintain the required standards. The link between post-operative infection and theatre air quality has been well established. Plants serving conventional operating departments, for instance, will be required to ensure the separation of areas within the suite by maintaining a specific direction of air flow between rooms, even when doors are opened. They will also maintain the selected operating department environmental conditions regardless of changes in the outside air conditions or activities within the space. In addition ultra-clean operating ventilation systems that are designed to provide an effectively particle-free zone around the patient while the operation is in progress, have been shown to reduce significantly post-operative infection in patients undergoing deep wound surgery. Their use for other forms of surgery may well be required.
- 1.18 Ventilation systems that can be shown to be inappropriate, inadequate or ineffective and that give rise to proven failures can result in a civil suit by the patient against the operators.
- 1.19 If the plant has been installed to dilute, extract or contain harmful substances (the definition of which now includes microorganisms) its failure may expose people to unacceptable levels of hazard. Proven failures can give rise to a civil suit against the designers and operators by the individuals who have been affected. This would be in addition to the actions brought as a result of breaching the statutory requirements.
- 1.20 There is a statutory requirement to provide ventilation in all enclosed workspaces. It may be provided by either natural or mechanical means. The following are some of the factors that determine the ventilation requirements of a workspace:
- human habitation (minimum fresh air requirement);
 - the activities of the department, that is, extraction of odours, aerosols, gases, vapours, fumes and dust – some of which may be toxic, infectious, corrosive, flammable, or otherwise hazardous (see Control of Substances Hazardous to Health (COSHH) regulations);
 - dilution and control of airborne pathogenic material;
 - thermal comfort;
 - the removal of heat generated by equipment (e.g. catering, wash-up, sterilising areas, electrical switch rooms, uninterruptible power supply (UPS) cupboards and some laboratory areas);
 - the reduction of the effects of solar heat gains where other forms of reducing the solar effect is not available or practical, i.e. solar blinds;

- the reduction of excessive moisture levels to prevent condensation (for example Hydrotherapy pools);
- combustion requirements for fuel burning appliances (see BS5376, BS5410 and BS5440);
- ‘make-up’ supply air where local exhaust ventilation (LEV) etc., is installed.

Mechanical ventilation systems are expensive in terms of capital and running costs, and planning solutions should be sought which take advantage of natural ventilation either where the use of the area in question is not critical to airflow patterns or pressures, or where backup systems are available when natural ventilation cannot be achieved.

1.21 When new ventilation systems are accepted for use, full information as to their designed mode of operation together with recommended maintenance procedures should be provided as part of the handover procedure.

Requirement	Reason	Application
Statutory	Health and Safety at Work etc Act	Operating department Laboratories Pharmacy
	COSHH regulations	Areas containing identified biological or chemical hazards Areas containing oxygen displacing gases
	Local Exhaust Ventilation (LEV)	Enclosed work-spaces Workshops
Functional	Comfort	Situations where the quality of the environment for staff and patients is critical to their general performance and well-being
Clinical	Post-operative infection reduction	Operating suites used for general surgery, casualty, obstetrics/gynaecological and maternity procedures
	Reduction of deep wound sepsis	Ultra-clean operating suites for transplant, deep wound surgery, hip replacement, bone grafting and bone marrow transplant procedures
	Isolation from contact with bio hazards	Isolation units for patients who present a biological, chemical or radiation hazard to others. Isolation units for patients with a reduced immune system

Table 1: Reasons for providing ventilation

Functional overview – Terms in use

1.22 The terms ‘ventilation’ and ‘air-conditioning’ are often incorrectly used to describe the same equipment. A general explanation of the terms is given below.

Ventilation

- 1.23 Ventilation is a means of removing and replacing the air in a space. In its simplest form this may be achieved by opening windows and doors. Mechanical ventilation systems provide a more controllable method. Basic systems consist of a fan and either collection, (extraction) or distribution (supply) ductwork. More complex systems may include the ability to heat and filter the air passing through them. Ventilating equipment may be required in order to remove smells, dilute contaminants and ensure that a supply of ‘fresh’ air enters a space.

Air-conditioning and mechanical cooling

- 1.24 Air-conditioning is the ability to heat, cool, dehumidify and filter air. For full air-conditioning, humidification may also be provided. This means that the climate within a space being supplied by an air-conditioning plant can be maintained at a specific level regardless of changes in the outside air conditions or the activities within the space. Mechanical cooling may be provided where close control of ‘comfort conditions’ within a space is required but humidity control is not needed.

Special ventilation

- 1.25 In healthcare premises, certain activities will necessitate the provision of ventilation equipment with additional special features in order to achieve and maintain specific conditions. These may be needed in order to assist with the treatment of patients or maintain the health and safety of staff. The precise reason for providing special ventilation will depend upon the intended application. The list below indicates some of the more typical reasons:

- to remove, contain or dilute specific contaminants and fumes;
- to ensure the isolation of one space from another;
- to preserve a desired air flow path from a ‘clean’ to a ‘less clean’ area;
- to provide control of the cleanliness of a space;
- to provide ‘close’ control of temperature;
- to provide ‘close’ control of humidity.

- 1.26 The following departments will usually have specialised ventilation requirements, either for a single room or throughout a suite of rooms:

- operating department;
- laser surgery unit;
- intensive treatment unit;
- infectious diseases isolation unit;
- manufacturing pharmacy;
- specialised imaging, X-ray and scanning unit;

- pathology containment laboratories;
- mortuary and dissection suite;
- research laboratory;
- sterilising and disinfecting unit (SDU);
- endoscopy unit;
- renal dialysis suite;
- ultrasound facilities;
- audiology room.

1.27 Ventilation may be provided in a wide variety of ways. These will include:

- extensive purpose-built air-conditioning units housed in their own plant rooms;
- proprietary 'packaged' systems often sited outside on a roof or;
- wall-mounted electric fans located at the point of use.

1.28 A fixed volume of air may be supplied, often expressed in terms of the resulting number of air changes per hour (ac/h) within the space being ventilated. It may also be expressed in terms of litres/second/person. Alternatively the volume of air supplied may be varied in order to maintain a specific pressure relationship between the area supplied and other surrounding areas. In some situations a combination of both methods may be adopted.

1.29 Modern plants are fitted with the means to recover energy from the extract air where this can be justified without causing contamination of the incoming supply air.

1.30 Ultra-clean systems use the same basic plant and equipment as standard air-conditioning but are in addition fitted with a terminal device that supplies the air in a unidirectional manner to the working area. Their standard of filtration will be capable of delivering air with a very low particle count to the space that they serve.

Local exhaust ventilation

1.31 Local exhaust ventilation (LEV) is a term used to describe systems installed to prevent hazardous substances from entering the general atmosphere of the room in which they are being used. Their primary function is to protect staff from the effects of their work activity.

1.32 Simple LEV systems comprise a capture hood, extract ductwork and fan. These are used to contain industrial types of hazard such as fumes from welding processes, gas discharges from standby battery banks and dust from woodworking machinery. The vapour given off when large quantities of chemicals are decanted into ready-use containers and fumes from X-ray film processing units are further examples of chemical hazards often controlled by LEV systems.

- 1.33 In laboratories, pharmaceutical manufacturing facilities and operating suites, LEV systems usually take the form of semi-open fronted cabinets within which the hazardous substance is manipulated. These cabinets either have their own filtered air supply or are fed with air from the room. The air extracted from the cabinet is passed through a high-efficiency filter before being discharged either to the atmosphere or back into the room. Microbiological safety cabinets, laboratory fume cupboards, cytotoxic drug cabinets and fixed or mobile disinfection enclosures are all examples of this type of facility.
- 1.34 Mortuaries and dissection suites may have LEV systems incorporated within the dissection table, specimen bench and bone saw.

Management action

- 1.35 The guidance contained in this SHTM should be applied in full to new installations and major refurbishments of existing installations.
- 1.36 Ventilation will need to be provided:
- as a requirement for patient care;
 - in order to fulfil a statutory duty.
- 1.37 In assessing the need for more specialised ventilation and the standards desired for patient care, managers will need to be guided by their medical colleagues and by information published by Health Facilities Scotland.
- 1.38 The statutory need for ventilation falls into two categories:
- in the first, the need for specialised ventilation and the standards to be adopted are clearly set out in specific pieces of legislation. An excellent example of this is the current legislation surrounding the manufacture of medicinal products in the European Community. The managers of the departments affected by this type of legislative requirement should be aware of their needs and be able to advise on the standards to be achieved;
 - the second type of statutory requirement arises due to the interpretation of both the Health and Safety at Work etc Act and the Control of Substances Hazardous to Health (COSHH) regulations. The person tasked with conducting COSHH assessments will be able to advise as to the need for, and standard of, ventilation in each particular case.

Design and validation process

- 1.39 It is essential when undertaking the design of a specialised ventilation system that the project be considered as a whole. The process model set out below should ensure that all relevant factors are considered.

Step	Question	Design statement and information required	Comment
1	Why is the system required?	Healthcare applications Statutory elements Non-healthcare applications	
2	What is the required system performance?	Room air flow pattern Air change rate Differential pressures Air quality Room air condition Noise limits	
3	What are the constraints on the distribution system?	Location, Size, Materials Dampers, Access, Insulation Fire considerations Room terminals	
4	What are the minimum requirements for the AHU(s)?	Intake / Discharge positions <i>Legionella</i> , Health and Safety Access, Fire, Electrical safety Leaks, Insulation, Cleanliness Filtration, Drainage	
5	What control functions are required?	User control requirements Estates control functions Energy management Environmental conditions Control sequence logic Run, Set back, Off philosophy	
6	How will the system performance be validated?	Validation methodology Instruments used Design information required [<i>Design air flow rates</i> <i>Design air velocities</i> <i>Pressure differentials</i> <i>Noise levels</i> <i>Air quality</i> <i>Installation standard</i>]	
7	The system will only be acceptable to the client if at the time of validation it is considered fit for purpose and will only require routine maintenance in order to remain so for its projected life.		
8	Handover to client	Basic design information Commissioning results Validation report	

Table 2: Design and Validation process model

Use and function of typical equipment used in ventilation plant

- 1.40 Typical equipment used in ventilation systems is listed below together with a brief description of both function and use.

General

- 1.41 The equipment built into the ventilation system and its ductwork should be of a type that will neither cause nor sustain combustion. No materials that could sustain biological activity should be used in the construction or assembly of the system.

Air Intake

- 1.42 An uncontaminated air supply to the system is essential. In order to achieve this, the air intake will be positioned so that air discharged from extract systems or other dubious sources cannot be drawn in. Exhaust fumes from vehicles can present particular problems. The area surrounding the intake will need to be kept clean and free of vegetation and waste material in order to reduce the possibility of biohazards or fire. The intake itself will be protected by a louvre and mesh screen to prevent rainwater, vermin and insects etc from entering the system.

Damper

- 1.43 Several types may be fitted:
- automatic dampers fitted immediately behind the air intake and extract louvres. They will automatically close when the system is shut down in order to prevent an uncontrolled circulation of air;
 - balancing dampers are fitted into each branch of the air distribution ductwork system so that the design air flow rate can be set during the commissioning process;
 - where ductwork passes through a fire compartment wall, ceiling or floor a fire and/or smoke damper may be required;
 - plant isolating dampers are fitted so that the main plant can be isolated from its air distribution duct system. They are manually operated and enable cleaning and maintenance of the air-conditioning equipment to be carried out.

Ducting

- 1.44 The means by which air is conveyed from the intake to its point of use. Ducting is usually constructed of galvanised steel and will normally be insulated to reduce noise and conserve energy. Ducts can also be formed in concrete, brickwork, stainless steel or plastic and may be rigid or flexible.

Fan

- 1.45 A series of rotating blades that move the air in the direction required. Fans are usually powered by electric motors either directly connected to them or driven through belts and pulleys. A fan may be arranged either to force air into or draw air from a ductwork system.

Attenuator / silencer

- 1.46 A device that will contain and absorb the noise emitted by a fan. They may be required to reduce disturbance caused by noise breaking out through the air intake and also noise transmitted along the ductwork to the conditioned space.

Filter

- 1.47 A filter consists of a labyrinth of fibrous material contained in a frame. It is designed to capture and hold particles being carried in the airstream. Because of the size range and number of particles that exist in air no filter can remove them all. The purpose of filtration is to reduce their number and size range to an acceptable level. Filters of progressively higher grades are fitted through the ventilation system:

- primary filters (coarse) are designed to collect the larger particles and are intended to keep the air-conditioning plant clean;
- secondary filters (fine) will remove the staining particles from air and keep the conditioned space visibly clean;
- high efficiency particulate air filters (HEPA/absolute) will remove virtually all particles from air. These may be required in order to reduce contamination in the working area either biologically or in terms of particle count.

Filters may be fitted to extract systems to protect energy recovery devices. They may also be fitted to remove biological, radiation or chemical hazards and if so, are often contained in a 'safe change' facility in order to protect those carrying out maintenance.

Activated carbon filters will reduce odours in extracted or recirculated air.

Heater battery / heater coils

- 1.48 A series of heater batteries or heating coils with or without fins through which steam or hot water is circulated. Heat is given up to the air passing over the battery thus increasing its temperature. Heating is usually carried out in stages, the final battery being controlled by the end user. Small batteries may be electric.

Humidifier

- 1.49 A device for increasing the humidity of air by adding moisture. For ventilation in healthcare premises this is normally achieved by releasing 'clean' steam into an

air supply duct. The steam will be completely absorbed into the air, increasing its humidity. The level of humidity may be preset or controlled by the end user.

Cooler battery / cooling coil

- 1.50 A series of finned coils mounted in the air supply duct. Either chilled water or refrigerant is circulated through the coils causing heat to be removed from the air. This will reduce its temperature and may also condense moisture out of the air. As free moisture in a duct can be a source of contamination the coil will be fitted with an eliminator and drainage system.

Eliminator

- 1.51 A device for catching and removing water droplets from an air stream. It may form part of a cooling coil or be a separate device.

Drainage system

- 1.52 A means of removing water from ductwork and disposing of it safely. Typically it will consist of a tray mounted in the duct to catch moisture, a glass water seal trap, continuously falling drainage pipework and an air break in the drain run to prevent waste water returning and contaminating the duct.

Access doors and observation ports

- 1.53 Doors and removable panels providing access for routine maintenance and cleaning. The doors should be fitted with glazed ports and suitable lighting provided so that the correct operation of devices such as cooling coils, humidifiers and filters can be easily observed without needing to switch off the plant.

Energy recovery

- 1.54 Many plants are fitted with the means to recover energy from the extract air without causing contamination of the incoming supply air. These devices will be fitted with a drainage system and may incorporate an eliminator. Several types of energy recovery systems are available.
- 1.55 Precise definitions of ventilation and air-conditioning terms are given in the Chartered Institution of Building Services Engineers (CIBSE) Guide B.

Typical plant

- 1.56 The layout of a typical plant that conforms to the requirements for healthcare applications is shown in [Figure 1](#) overleaf. It contains most of the equipment described above.

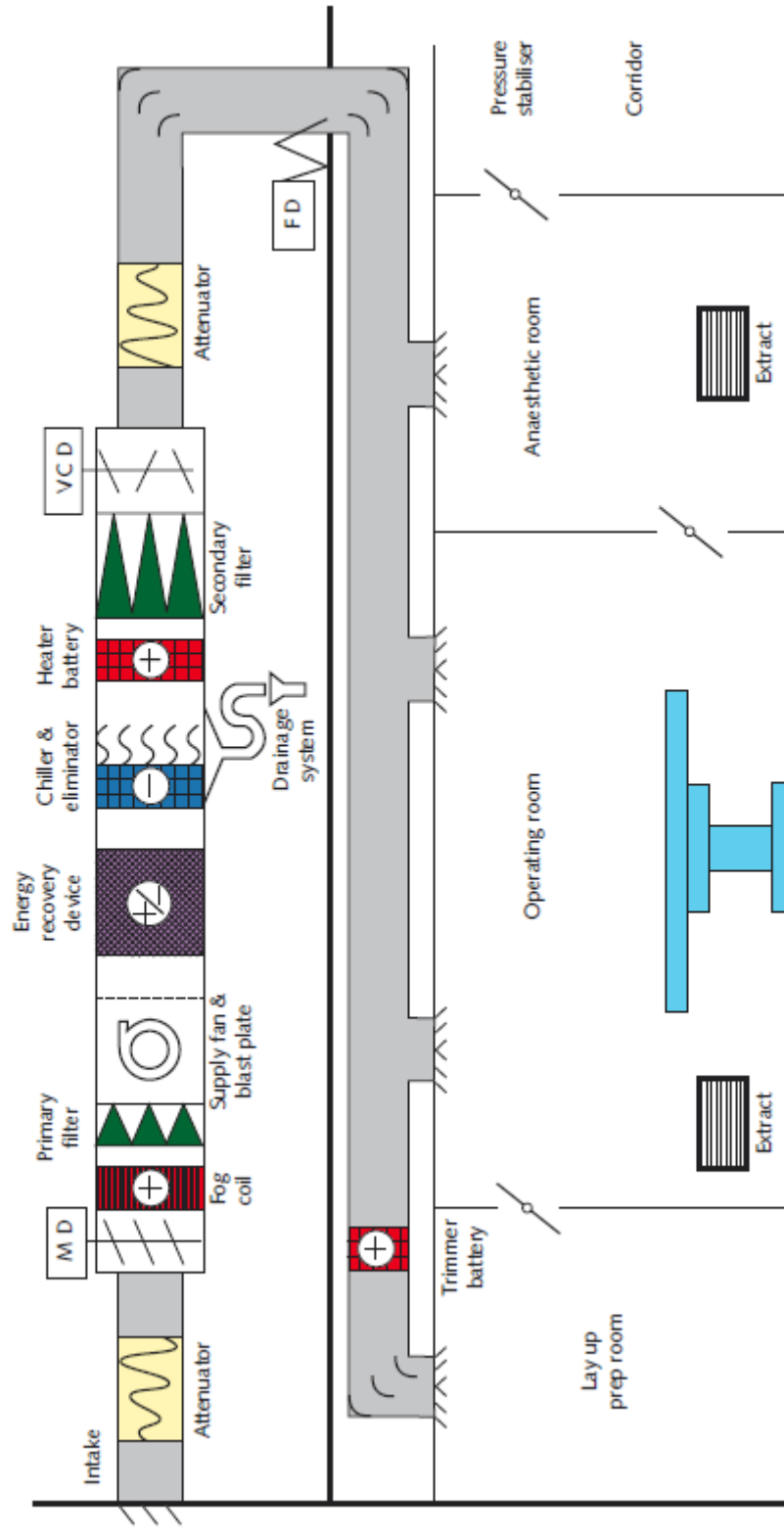

Figure 1: Design and Validation process model

2. Provision of ventilation in healthcare buildings

- 2.1 It is acknowledged that planning constraints imposed by the building shape and/or functional relationships of specific areas will invariably result in some measure of deep planning thus reducing the opportunity for natural ventilation. However, ventilation costs can be minimised by ensuring that where practicable, core areas are reserved for rooms that have a functional requirement for mechanical ventilation. Examples are sanitary facilities, dirty utilities and those rooms where clinical or functional requirements have specific environmental needs; and where for reasons of privacy, absence of solar gain etc., windowless accommodation is acceptable. Other spaces appropriate to core areas are those that have only transient occupation and therefore require little or no mechanical ventilation, for example circulation and storage areas.

Natural ventilation

- 2.2 Natural ventilation is usually created by the effects of wind pressure. It will also occur if there is a temperature difference between the inside and the outside of the building. The thermo-convective effect frequently predominates when the wind speed is low and will be enhanced if there is a difference in height between inlet and outlet openings. Ventilation induced by wind pressures can induce high air change rates through a building provided air is allowed to move freely within the space from the windward to the leeward side.
- 2.3 As the motivating influences of natural ventilation are variable, it is almost impossible to maintain consistent flow rates and ensure that minimum ventilation rates will be achieved at all times. This variability is normally acceptable for general areas including office accommodation, general wards, staff areas, libraries rooms, dining rooms and similar areas which should, where possible, be provided with opening windows of a design that facilitates natural ventilation.
- 2.4 Current guidance restricts the amount windows can be opened for safety reasons and as many designs are top-hung, their ability to permit natural ventilation is limited. It may therefore be necessary to provide dedicated ventilation openings in the fabric of the building to allow a sufficient natural flow of air into and out of the space. [Paragraph 2.20](#) also refers.
- 2.5 In all cases, excessive heat gain, indoor air quality requirements or external noise may limit or preclude the use of natural ventilation.

Extract ventilation systems

- 2.6 Separate extract ventilation will be required for sanitary facilities, lavage areas, dirty utilities and in rooms where odorous, but non-toxic fumes are likely, in order to ensure air movement into the space. 10 air changes per hour have been found necessary, particularly in geriatric and psychogeriatric

accommodation. This will assist with infection control procedures. A single fan/motor unit can be suitable for individual rooms, but multi-room systems should be provided with duty and standby fans or motors to meet this need.

- 2.7 Toilets should have an extract ventilation rate as set out in the building regulations. Where WC's are located in shower and bathroom spaces, the ventilation required for the WC will normally be adequate for the whole space.

Supply only ventilation

- 2.8 Mechanical supply ventilation will be required in areas where it is important to maintain a positive pressure in order to prevent the ingress of less clean air, e.g. in pharmacy aseptic suites, sterile supply packing rooms, operating theatres and their preparation rooms (air change rates are given in [Table A1](#)).

Supply and extract ventilation

- 2.9 Mechanical supply and extract ventilation should be provided in rooms where there is a need to control room pressure in relation to adjacent spaces. Intensive Care Units, (ICU), isolation suites and treatment areas are typical applications.

Mechanical or comfort cooling

- 2.10 Cooling is very expensive in terms of energy costs and should be provided only where necessary to maintain a comfortable environment for staff and patient, or to ensure satisfactory operation of equipment. The imaging department in particular may require cooling to offset the equipment load.
- 2.11 Calculations and thermal modelling should be undertaken to ensure that during the summertime, internal temperatures in patient areas do not exceed 28°C (dry bulb) for more than 50 hours per year taking into account the level of design risk for the application.
- 2.12 Certain non-patient areas may also require cooling and will typically include some laboratories, central wash-up and other areas that are subject to high equipment heat gains.
- 2.13 Where deep planning of other continuously occupied spaces, for example offices, is unavoidable, there will also be occasions when acceptable levels of comfort can only be maintained by cooling. Planning solutions of this type however will be exceptional.
- 2.14 Refrigeration plant should be of sufficient capacity to offset heat gains and maintain areas at a temperature that does not exceed the external design shade temperatures by more than about 3°C taking into account the level of design risk for the application.

Air-conditioning

- 2.15 Full air-conditioning is only required in a very small number of areas within healthcare buildings and due to the capital and running cost its inclusion should be kept to a minimum. [Paragraphs 3.14 - 3.15](#) and [4.91 - 4.93](#) also refer.
- 2.16 Areas whose functions may warrant the installation of air-conditioning include operating departments, intensive therapy units, manufacturing pharmacies and areas with particularly sensitive equipment.

Specialised ventilation

- 2.17 Due to the nature and extent of activities carried out in healthcare buildings, there will be a need for a wide range of specialised ventilation systems. The types of system which are generally required in individual departments and typical arrangements are given in [Section 7](#).
- 2.18 The activities within some departments will require the provision of local exhaust ventilation (LEV). This is a statutory requirement under COSHH wherever the escape of chemicals, toxic fumes, biological material or quantities of dust into the general area would present a hazard to the occupants.

Ventilation for general areas

- 2.19 [Table A1](#) provides recommended air change rates, temperatures and pressures for general areas that require mechanical ventilation in healthcare buildings.

Use of natural ventilation

- 2.20 The air tightness of new buildings has improved to the point that infiltration through building leakage can no longer be relied upon to provide sufficient air-flow. Attention must therefore be given to the provision of purpose-made ventilation openings to achieve the necessary flow rates. The air entering the openings may need to be controlled by motorised dampers linked to temperature and / or occupancy sensors in the ventilated space.
- 2.21 Internal partitions, fire compartment walls and closed doorways can often impede the flow path, and when this happens, the process will be more dependent on single-sided ventilation. Nevertheless, even with this degree of compartmentation, acceptable ventilation may still be achieved without window openings that would prejudice safety, security or comfort.
- 2.22 Some types of window, for example, vertical sliding, can enhance single sided air change by temperature difference, and these will improve the overall rate of natural ventilation in protected or sheltered areas where the effect of wind pressure is likely to be minimal.
- 2.23 It is generally considered that natural cross-flow ventilation is able to give reasonable air distribution for a distance of up to 6 metres inwards from the

external façade, provided that reasonably clear air paths are maintained. Beyond this distance in areas where clear air paths cannot be maintained and in areas where high minimum air change rates are specified, mechanical ventilation should be provided.

- 2.24 Further information can be found in SHTM 55 ‘Windows’, BS5925 ‘Code of practice for ventilation principles and designing for natural ventilation’ and CIBSE Applications Manual AM10: ‘Natural ventilation in non-domestic buildings’.

Mixed mode ventilation

- 2.25 This comprises an assisted form of natural ventilation. Fans are fitted in the purpose made damper-controlled ventilation openings. Alternatively a separate ventilation unit may be installed. In both cases the dampers and fans are controlled under the dictates of temperature and occupancy sensors to ensure a minimum air flow rate while taking advantage of natural ventilation effects when present.
- 2.26 Where natural or mixed mode ventilation is adopted with complex air paths, the designer should produce an air flow diagram in order to ensure correct provision of air transfer devices. CIBSE Applications Manual AM13: ‘Mixed mode ventilation in non-domestic buildings’ gives guidance.

Mechanical extract ventilation

- 2.27 General extract systems can vary in complexity from a single wall-mounted fan to a ducted air system with dual extract fans.
- 2.28 Replacement air is generally provided by a central supply system (as described below). Unless special precautions are taken, the latter may result in an unacceptable level of draughts occurring in winter, and possible risk of unacceptable levels of noise transmission.
- 2.29 If individual systems are used, the ventilation can be operated intermittently, provided it continues to run for at least 15 minutes after the room is vacated, as with light switch-operated fans in individual toilets.
- 2.30 If general exhaust systems are used; it is recommended that filtered and tempered replacement air is provided via a central supply plant to adjoining lobbies or corridors, to prevent the risk of discomfort caused by the ingress of cold air. Fire compartmentation requirements must be maintained.
- 2.31 Information on specialised extract systems is given in [Section 7](#).

Mechanical supply systems

- 2.32 Where mechanical supply systems are required, the fresh air should be tempered and filtered before being delivered to the space, to avoid discomfort.

- 2.33 The air should be heated using a constant or variable temperature source, but generally only to the space air temperature. In most instances, the low-pressure hot water heating (LPHW) should offset any fabric loss, so that setback room temperatures can be maintained during unoccupied periods without the need for the ventilation system to operate.

Balanced ventilation

- 2.34 Balanced ventilation systems are merely a combination of a supply and extract systems of equal volume; and either a single space or a whole building may be considered to be balanced. A balanced system is necessary in instances where it is essential to maintain consistent air movement within an area, for example, treatment rooms.

Cascade ventilation

- 2.35 In operating departments it is normal practice to supply air to the operating room, and allow it to pass through less clean areas – corridors, utility rooms etc. (from where it is eventually extracted).

Recirculation systems

- 2.36 Due to the nature of the use of mechanical ventilation systems within healthcare buildings, there are few opportunities for the application of recirculation air systems. They are however normally used for HEPA filtered clean room applications where the extract air is significantly cleaner than the outside supply. Recirculation is also routinely used in the canopy section of Ultra Clean Operating theatre ventilation systems.
- 2.37 Where the designer is considering the installation of a recirculation air system, due account must be taken of:
- minimum fresh air supply volume required by the Building (Scotland) Regulations 2004 (currently 20%);
 - prevention of contamination of supply air from vitiated air in extract systems;
 - prevention of stratification occurring within plenum chambers and mixing boxes which may result in freezing of downstream coils;
 - ensuring sufficient velocities through control dampers (ideally 5-6m/s) to provide suitable authority; and good shut-off;
 - modulating control of mixing to provide optimum on-plant conditions;
 - use of 'free cooling' by cycling the dampers to minimum fresh air when the enthalpy of the outside air is above that of the extract air under conditions when cooling is required.

Chilled beams

- 2.38 The use of chilled beams for the provision of heating, cooling and ventilation is increasingly common in healthcare premises. The use of Active Chilled Beams providing tempered filtered air to a heating / cooling device within the room can provide effective local control of environmental conditions.
- 2.39 Care should be taken in positioning chilled beams to ensure the avoidance of cold draughts particularly when used in the cooling mode. The control settings should ensure that the external elements of the beam are always above dewpoint.
- 2.40 Consideration should be given to the ease with which specific types of chilled beam units can be accessed for cleaning having regard to the need to control the infection risk. The impact of maintenance requirements on room availability should also be considered.

Split comfort air-conditioners

- 2.41 Split comfort air-conditioners, room conditioners or cassette units are used increasingly where there is a small local requirement for cooling for operational purposes. They can provide an effective economic solution to cooling needs, where a central refrigeration system is not practicable.
- 2.42 The units re-circulate room air so provision for a fresh air make up, either by natural or mechanical means, to the standard required by the Building (Scotland) Regulations must be provided.
- 2.43 The recirculation of room air presents problems with indoor air quality (IAQ) and may increase the risk of healthcare associated infection (HAI). Split units should not therefore be used in critical patient areas.
- 2.44 Split units may be used for single room applications or as multiple linked units that can independently provide either heating or cooling, all served by a single outdoor unit. These systems enable good temperature control of a number of rooms with maximum energy efficiency.
- 2.45 Whether single or multiple systems are used, it is essential that the designer gives due consideration to the source of electrical supply, location of the heat rejection unit, environmental effects to the refrigerant used and drainage provision for the cooling coil condensate.
- 2.46 The units will require routine maintenance for filter change and cleaning; they should therefore be installed in an accessible position.

Dilution ventilation and clean air flow paths

- 2.47 Dilution ventilation has in the past been used to control levels of hazardous substances in a space. This approach is no longer considered acceptable. The COSHH Regulations require that known hazardous substances should

be substituted by safe alternatives. If this is not possible then they should be controlled at source by the use of closed systems such as anaesthetic gas scavenging units or exhaust protective enclosures such as fume cupboards.

- 2.48 The exposure of staff to casual spillages of substances such as medical gases in anaesthetic rooms should in the first instance be dealt with by establishing a clean airflow path. Air should be supplied at high level and extracted at low level directly behind the anaesthetic equipment position. The philosophy of establishing a clean air-flow path from the supply point; to the staff; on to the patient and out via a low level extract would also apply in recovery rooms and maternity delivery rooms including labour, delivery, recovery & post partum (LDRP) Rooms. A suitable air change rate will provide dilution ventilation as an additional safeguard; see [Table A1](#), [Table A2](#) and [Note c](#).
- 2.49 In operating theatres the patient will be on a closed breathing circuit in a room with a high air change rate. Under these circumstances the dilution effect would be considered sufficient to control any casual exposure to anaesthetic gases.

Mechanical ventilation systems

System selection

- 2.50 Natural ventilation is always the preferred solution for a space, provided that the quantity and quality of air required, and the consistency of control of ventilation to suit the requirements of the space, are achievable with this method. If this is not the case, a mechanical ventilation system will be required.

Choice of central/local plant

- 2.51 Mechanical ventilation is expensive to operate, and as such, should be controlled to operate when the space being served requires to be ventilated. In addition, loads on refrigeration plant are rarely constant owing to changes in solar gain, occupancy and use of heat-generating equipment and lights, therefore control of temperature is critical.
- 2.53 If the ventilation loads throughout a department or building are in phase, or are not significant, a central plant with single zone control can be adopted. However, this is rarely the case, and elsewhere, the condition or quantity of supply air to different areas or zones of the building must be varied accordingly. This can be done by providing either individual plants to each zone, or separate zone terminal control. Where there is a high density of rooms with similar ventilation requirements in an area of a building or department, it is usually economical to combine them into a central system.
- 2.54 In large buildings, a choice between a single distribution system and multiple smaller systems may arise. Large distribution systems and their plant can have the advantage of lower operating costs, but require more space for vertical shafts and horizontal distribution. In general, very long runs of ducting should be avoided to prevent undue heat losses or gains, excessive leakage, and difficulties in balancing during commissioning. As the pressure losses in the

long runs will be greater and a higher initial static pressure will be required, this will lead to a more expensive class of ductwork. Multiple smaller distribution systems may be more expensive in capital and operating costs but they avoid long runs, large ducts and vertical shafts, and this may reduce overall building costs. They also provide a more robust service as the failure of an individual system does not prevent the use of the rest of the building.

Zoning of the building

- 2.55 The efficiency and effectiveness of any ventilation or air-conditioning installation depends largely on the zoning and control of the installation. The factors to consider when determining the zoning of a ventilation system for a building or department are:
- periods of occupancy;
 - fresh air/ventilation requirements;
 - smoke control.
- 2.56 Where the ventilation system is not merely tempering the air, but also providing the heating and/or cooling requirements, the following additional factors will need to be considered:
- internal or peripheral location;
 - orientation of windows;
 - variation in internal loads;
 - level of control required.
- 2.57 For single zone plant in staff areas, local control (with a run-on timer if required) is recommended, as this can be turned off when the space is not in use, thus saving both thermal and electrical energy. Most supply and extract systems, conversely, are required to operate continuously while the department is occupied, thus some form of time or use control is necessary.
- 2.58 The control of individual plant items is covered in [Section 4](#), with examples of typical control strategies in [Section 6](#). For control of particular specialised ventilation and air-conditioning systems refer to [Section 7](#) of this document.
- 2.59 On very rare occasions a duplicate standby air handling plant may be justified. If installed it must be provided with a gas-tight damper at its junction with the supply distribution duct, so that no back-flow can occur. Standby plants can become sources of contamination if warm moist air is allowed to dwell within them. Their design and control system must ensure that this cannot happen.

Specific requirements for hospital departments

- 2.60 Specific requirements for individual spaces and departments are included in the Health Building Notes (HBNs) and Activity Database (ADB) A-Sheets, or Scottish Health Planning Notes (SHPNs).

3. Assessment of service requirement

Selection of design criteria

External design conditions

- 3.1 The most accurate data that is available for the summer and winter conditions at the site should be used. The Metrological office can supply data for the United Kingdom.
- 3.2 Healthcare mechanical ventilation systems will normally be 'full fresh air'.
- 3.3 Local adjustments such as for height above sea level, exposure factor, or other climate peculiarities, should be made as appropriate.

Internal design conditions

- 3.4 The design conditions selected within patient areas must strike a balance between the comfort requirements of staff and patients, who often have very different levels of clothing and activity.
- 3.5 Recommendations for the dry resultant temperature and humidity of individual spaces are shown on Activity Database (ADB) A-Sheets. [Table A1](#) gives a summary.

Minimum fresh air requirements

- 3.6 For most applications involving human occupancy, the dilution of body odours is the critical factor in determining ventilation requirements. Where natural ventilation or mechanical full fresh-air systems are used, all ventilation air will be fresh.
- 3.7 Where odour dilution is the overriding factor, it is recommended that 10 litres/second/person should be taken as the minimum ventilation rate.
- 3.8 Smoking is not permitted in healthcare premises. If permitted for example in residential care, it will be confined to designated areas. It therefore follows that these areas will contain a high percentage of smokers so the ventilation rate would be at least 36 litres/second/person for these applications (CIBSE Guide A; Table 1.10 refers).
- 3.9 In non-standard applications such as laboratories, aseptic suites, operating departments, etc., the particular requirements for each area should be considered independently in order to determine the overriding minimum requirement for ventilation.

Limiting supply air conditions

- 3.10 For most applications in healthcare buildings, it is the temperature differential between the supply and room air, rather than the actual temperature of the supply air which is the critical factor. The maximum recommended supply-to-room air temperature differential is:

summer cooling: - 7K

winter heating: + 10K

- 3.11 It is also necessary to keep supply air humidity below 70% during winter in order to minimise risks associated with condensation.

Air purity

- 3.12 In healthcare premises, the standard of filtration will depend on the activities within the occupied spaces. With the exception of special areas, (for example manufacturing pharmacies), the requirement for aerobiological needs is not stringent and filtration is only required to:

- maintain hygienic conditions for the health and welfare of occupants, or for processes such as food preparation;
- protect finishes, fabrics and furnishings; to reduce redecoration costs;
- protect equipment either within the supply air system; that is, to prevent blocking of coils, or in the space itself to prevent dust collection.

- 3.13 Given that almost all viable particles will originate from the occupants of a space and not from the incoming air, dilution is the more important factor aerobiologically. Therefore, for general areas a G4 filter will be suitable. More critical areas will require a F7 filter. HEPA filters will only be required in Ultra Clean systems.

Humidity control requirements

- 3.14 Providing humidification is expensive in terms of plant, running costs and maintenance, and therefore its use should be restricted to where it is necessary for physiological or operational reasons.
- 3.15 Humidification was originally required for some healthcare applications, e.g. operating theatres, in order to control the risk associated with the use of flammable anaesthetic gases. The use of such gases has now ceased. Humidification is therefore no longer required unless there is a very specific application requirement.

Maximum noise levels

- 3.16 Noise will be generated in an air distribution system by the fan, ductwork fittings, dampers and grilles. The specified maximum noise level will depend on the activities within the occupied spaces.
- 3.17 The overall noise levels should not exceed the values given in Scottish Health Technical Memorandum 08-01: 'Acoustics', although general requirements are given in [Table 3](#).
- 3.18 Attenuation should be incorporated into the ductwork system or plant arrangement as necessary to reduce noise from fans and plant items in order to achieve the acceptable limits within the rooms at the design air flows.
- 3.19 Plant noise should not be greater than 80dB(A) within the plant room from the fans, coolers, heaters, humidifiers etc. when starting up or running, and should be reduced to lower noise levels where the plant is near to departments sensitive to noise.
- 3.20 Attention must be given to the reduction of tonal components. High tonal components from air diffusers etc. can seriously disturb concentration over longer periods even when the overall noise level is low. Broadband noise causes less annoyance. Reference should be made to SHTM 08-01: 'Acoustics'.
- 3.21 The designer requires knowledge of the total hospital layout and operational policies, to assign acceptance magnitudes to all the possible noise sources, in order to arrive at the correct rating.

Room	Overall noise level - NR	Ventilation plant commissioning - NR	Ventilation plant design - NR
Operating department	50 (55)	45	40
Ward areas	33	30	30
Sanitary facilities	45	40	35
Industrial areas	50	45	40
Circulation areas	50	45	40

Table 3: Interior noise level

- 3.22 In Table 3, above, the overall noise level takes account of all internal and external noise sources. The commissioning noise level is the level measured with a sound level meter in the unoccupied room, taking account of the external noise together with the noise generated by the ventilation system. When occupied and in use, this commissioning level will constitute a continuous background noise which will allow the overall noise level to be achieved. The ventilation plant design noise level is that generated by the plant alone with no other noise source being considered. The levels suggested make recognised allowance for the ingress of environmental noise that must be considered in the overall design, that is, in specifying the attenuation of walls, partitions, ceilings, etc.

- 3.23 The recommended criterion is measured as the “A” weighted sound pressure level expressed in decibels, which should not be exceeded for more than 10% of the time.
- 3.24 The designer must also consider noise escaping to the external environment and this must not be unacceptable to occupants of adjacent buildings.

Calculation of building loads

Air infiltration

- 3.25 Air infiltration occurs due to a complex combination of wind pressure, thermal effects, location relative to other features and the construction standard of the building. The infiltration rate is governed by the size and number of openings in the building envelope and the complexity of internal air paths.
- 3.26 CIBSE Guide A (2006) Section 4 provides information and formulae for the calculation of air infiltration and natural ventilation of buildings. In all cases the requirements of the appropriate section of the Building (Scotland) Regulations must be met.

Summertime temperatures

- 3.27 The calculation method for determining the summertime temperature is described CIBSE Guide A (2006) Section 5. However, it is very important to select the time of day and time of year of peak loadings for the calculations. These will be dependent on the orientation and proportion of solar to total heat gain. In establishing outside design values, the design risk having regard to the function and occupancy of the building should be considered.
- 3.28 Where calculations indicate that internal temperatures will frequently exceed the selected design external shade temperature by more than 3K for a period that exceeds the building design risk, methods of reducing temperature rise should be implemented. Options include: - reducing solar and casual gains, the use of chilled beams or ceilings, increasing ventilation rates or providing mechanical cooling. In some situations it may be possible to alter the thermal mass of the structure to ‘move’ the peak temperature event time so that it occurs outside of the occupancy period. Calculations and thermal modelling should be undertaken to ensure that during the summertime internal temperatures in patient areas do not exceed 28°C dry bulb for more than 50 hours per year. It has been found that there is a relationship between preferred indoor temperatures and mean outside temperature. Fig A2 in CIBSE Guide A indicates this relationship.

Peak heating load

- 3.29 Peak heating local calculations are necessary on all mechanical supply systems to establish the size of heater batteries and subsequently the central plant.

- 3.30 Where ventilation systems provide tempered air to spaces that have supplementary LPHW to offset the building fabric losses, the plant heating load should be calculated based on the external winter design temperature, the design internal air temperature, and the calculated total air volume (including a suitable allowance for leakage).
- 3.31 Where the ventilation system is the only means of heating a space, an increase in load equivalent to the calculated fabric heat losses from the space should be added to the ventilation load. A check of supply temperature difference should be made. If it exceeds 10K the ventilation supply volume should be increased to suit.

Condensation risk

- 3.32 A check should be made to ensure that the selected air condition will not lead to surface condensation on low-temperature elements of the ventilated space.
- 3.33 Where there are local sources of moisture that would require excessive levels of ventilation to avoid condensation, the designer should consider the capture and removal of moisture at the source of the evaporation via an exhaust hood or similar device.
- 3.34 In intermittently heated buildings, it is necessary to consider the condensation risk at night setback conditions as well as during normal operation. Calculation methods for this assessment are given in CIBSE Guide A.

Peak cooling load

- 3.35 In addition to the base data of airflow rates and temperatures, when calculating cooling loads, the designer must take into account:
- solar cooling loads;
 - surface conduction cooling loads;
 - internal gain cooling loads;
 - cooling loads due to high-level humidity control;
 - method of control of internal conditions;
 - fluctuations in internal temperatures.
- 3.36 When the peak internal loads have been assessed and a suitable allowance made for non-coincidence, the supply temperature can be calculated.
- 3.37 Once the lowest required supply temperature of the air handling unit has been established, and an allowance made for temperature rise through the fan and ductwork (usually 1K for low pressure systems), the off-plant enthalpy can be established from a psychrometric chart or table.
- 3.38 The cooling loads for all plants on the chilled water system should be calculated at each of the individual peak times in order to establish accurately the required (diversified) capacity of the chiller.

Annual energy consumption

- 3.39 Annual energy consumptions of heating-only ventilation systems are simple to calculate based on supply-to-external air temperature rise, and frequency of occurrence of external temperatures as given in CIBSE Guide A.
- 3.40 Minimum air volumes are usually fixed by the room loads or fresh air requirements. However, the designer may increase airflow to some rooms or zones in order to balance loads, as detailed in the following paragraphs on “Calculation of plant requirements.”
- 3.41 The method of zoning and control can significantly influence energy consumption.
- 3.42 The nature of air-conditioning operation, comprising cooling and reheating for humidity or zonal temperature control, makes prediction of energy consumption very complex. It is imperative that these calculations are performed to ensure optimum energy efficiency.
- 3.43 The concept of load and plant operation charts is outlined in the CIBSE Guide A. The method requires the designer to establish the minimum and maximum loads on all zones across the range of external temperatures between winter and summer design conditions. Once the load chart is complete, the plant chart converts the loads to supply temperatures, which are then superimposed on external air temperatures.
- 3.44 When all temperatures for all zones are plotted on the plant operation chart, set points and resetting schedules can be established. From this information, the outputs of individual heaters, coolers and humidifiers can be established at any given external temperature. When those loads are computed against annual frequency of occurrence of external temperatures as given in CIBSE Guide A, the annual energy consumption of individual elements, and thus the air-conditioning system, can be established.
- 3.45 In order to prevent surface condensation occurring, it is necessary to provide sufficient ventilation to maintain the maximum and ambient dew-point temperature below the lowest surface temperature, the coldest usually being the glazing. [Paragraphs 3.33 and 3.34](#) also refer.

Calculation of plant requirements

Air supply volumes

- 3.46 The minimum air supply volume for a room is determined by the greatest of these three criteria:
- the minimum fresh-air requirement;
 - the minimum supply volume for the room load as determined by the maximum heating or cooling supply temperature differential;
 - the desired/required air change rate.

Plant sizing

- 3.47 Once the design airflow has been established the cross-sectional area of the air-handling unit can be calculated based on a maximum coil face velocity of 2.0 m/s.
- 3.48 In order to establish the length of the air-handling unit, it will be necessary to refer to manufacturers' literature, ensuring all necessary access panels and components are included as detailed in [Section 4](#).
- 3.49 The fan duty should be calculated by adding the resistances of all elements that contribute to the pressure drop of the index circuit.
- 3.50 The main elements that must be considered are:
- inlet or discharge louvres;
 - plant entry and discharge;
 - attenuators;
 - components within the air-handling unit;
 - duct-mounted heaters and filters (including a dust allowance);
 - ductwork distribution;
 - ductwork fittings, including: fire dampers, volume control dampers, bends and sets, tees, changes of section;
 - air terminal device;
 - discharge velocity.
- 3.51 Where packaged air-handling units are installed, the fan pressure drop is usually quoted as external plant resistance, and thus the designer does not need to calculate the resistances of individual plant items. The designer should, however, ensure that an allowance has been made for filter clogging; and confirm whether the fan pressure quoted is fan total or static pressure.
- 3.52 Resistances of ductwork and fittings may be obtained from the CIBSE Guide A. However, the designer should exercise some care when using tabulated pressure loss information for fittings that are relatively close together.
- 3.53 Upon completion of the resistance calculation exercise, the designer should make allowances for calculation and construction tolerances as indicated in [Table 4](#).

Criteria	Low pressure systems	Medium/high pressure systems
Volume flow rate margin for leaking and balancing requirements	+5%	+5%
Total pressure loss margin		
A. for increase in volume flow rate (above)	+5%	+5%
B. for uncertainties in calculation	+5%	+10%
Combined total pressure loss margin	+10%	+15%

Table 4: Typical fan volume and pressure margins

Plantroom size and location

- 3.54 The ventilation plant and associated equipment should be positioned to give maximum reduction of noise and vibration transmitted to sensitive departments; while at the same time, achieve an economic solution for the distribution of services.
- 3.55 It is not recommended that noise and vibration generating plant be housed either directly above or below sensitive areas (for example, operating or anaesthetic rooms) unless there is no alternative, in which case, additional care and attention must be given to the control measures.
- 3.56 The plant must also be located so that it is remote from possible sources of contamination, heat gains and adverse weather conditions. The design should ensure that wind speed and direction have a minimal effect on plant throughput.
- 3.57 Safe access to and around plant is essential to facilitate inspection, routine maintenance, repair and plant replacement.

Provision of primary services

- 3.58 Where more than one air-handling plant requires cooling, remote central cooling plants with piped chilled water are preferred. In the case of a single plant, a multi-stage direct-expansion cooling coil with refrigerant piped from an adjacent compressor/condensing plant could be considered. If this option is selected, a refrigerant gas detector mounted in the base of the duct and an alarm system audible to the end-user will also need to be provided (as dictated by COSHH Regulations).
- 3.59 Clean dry steam is preferred for humidification, provided that the boiler water treatment does not render the steam unusable for direct humidification.
- 3.60 If a suitable supply of steam cannot be obtained from the steam main, a steam generator should be provided locally, or a self-generating humidifier installed. Electric humidifiers require considerable electrical loads and if a gas supply can be derived, this would be preferable. The location of a local steam generator is critical if condensate is to drain back into it.

Inlet and discharge sizing and location

- 3.61 Air intakes and discharge points should preferably be located at high level, to minimise the risks of noise nuisance to surrounding buildings, contamination and vandalism.
- 3.62 Intakes and discharges should be designed and located so that wind speed and direction have a minimal effect on the plant throughput.
- 3.63 Helicopter landing pads in the vicinity of ventilation intakes and discharges can result in large short-term pressure changes. This can cause pressure surges in supply systems and reverse airflows in extracts. Exhaust fumes from the helicopter may also be drawn into intakes. For general information, refer to Health Building Note (HBN) 15-03 – Hospital helipads.
- 3.64 Intake points should also be situated away from cooling towers, boiler flues, vents from oil storage tanks, fume cupboards and other discharges of contaminated air, vapours and gases, and places where vehicle exhaust gases may be drawn in.
- 3.65 Where intakes have necessarily to be sited at or near ground level, the area around them should be paved or concreted to prevent soil or vegetation being drawn in. They should also be caged or located within a compound to prevent rubbish being left in the vicinity. The likely proximity of vehicle exhausts should also be taken into account when determining the protected area around the intake.
- 3.66 The discharge from an extract system must be located so that vitiated air cannot be drawn back into the supply air intake or any other fresh-air inlet. Ideally, the extract discharge will be located on a different face of the building from the supply intake(s). In any event, there must be a minimum separation of 4 metres between them, with the discharge mounted at a higher level than the intake.
- 3.67 Discharges from LEV systems should preferably be vertical and usually not less than 3m above roof level. They should not be fitted with a cowl that could cause the discharge to be deflected downwards.
- 3.68 Each intake and discharge point should be fitted with corrosion-resistant weatherproof louvres or cowls to protect the system from driving rain. Louvres should be sized based on a maximum face velocity of 2 m/s in order to prevent excessive noise generation and pressure loss.
- 3.69 The inside of the louvres should be fitted with a mesh of not less than 6mm and not more than 12mm to prevent leaves being drawn in and infestation by vermin.
- 3.70 The duct behind louvres should be self-draining. If this is not practicable, it should be tanked and provided with a drainage system.

- 3.71 Cleaning access must be provided either from the outside via hinged louvres or by access doors in the plenum behind the louvre. Where a common plenum is provided, cleaning access should be via a walk-in door.

Heat rejection devices

- 3.72 The design conditions given in [Section 2](#) make no allowance for the elevated temperatures that can occur on the roof of buildings. Refrigeration condensers and cooling towers should, if practicable, be shaded from direct solar radiation, or the design adjusted to take account of the gain.
- 3.73 Air-cooled condensers must always be the first choice for heat rejection from any refrigeration plant. Evaporative cooling systems must not be used in healthcare premises unless limitations of space mean that they are the only way that the cooling load can be met. If they are used, national guidance on preventing and controlling *Legionella* must be closely followed.
- 3.74 Reference should be made to Scottish Health Technical Memorandum 04-01: 'The Control of *Legionella*, hygiene, 'Safe' hot water, cold water and drinking water systems, Part A: Design, Installation and Testing, and Part B: Operational Management, published by Health Facilities Scotland, 2011.

4. Air handling unit design and specification guidance

General requirements

Location and access

- 4.1 Air-handling units should be located in an accessible area secured from unauthorised entry. Siting units in ceiling voids above occupied spaces is not appropriate.
- 4.2 Units located on roofs must have a safe means of access together with suitable precautions to prevent personnel or equipment falling or being blown off during maintenance activities.
- 4.3 Units located at ground level should be secured within a locked compound to prevent unauthorised access. Measures should be taken to exclude vehicles from the vicinity to ensure that exhaust fumes will not be drawn into intakes.
- 4.4 Units may have a working life of approximately 20 years. It can be anticipated that over this period there will be a need to access every element within the unit for deep cleaning. It is also quite possible that the main fan and individual heater and chiller batteries will need replacement. Suitably positioned service connection joints and adequate spacing should permit these items to be withdrawn without the need to dismantle other installed plant or equipment. Batteries significantly wider than 1 metre should be split to permit withdrawal from both sides.
- 4.5 It is essential that air-handling units are positioned so that all parts are easily and safely accessible for routine inspection and service. If a unit is located against a wall or backs onto another unit then access to all parts must be available from the front. Units greater than 1 metre wide should preferably have access from both sides or access doors large enough to permit the full and safe entry of maintenance personnel.
- 4.6 Water may be used during routine cleaning or spilt when maintenance is being undertaken. The area around the unit should be tanked to prevent water penetration to adjacent areas and adequately drained.
- 4.7 Fire precautions should be incorporated in accordance with Firecode. Guidance is available in BS5588: Part 9 and [Sections 5 and 6](#) of this document.
- 4.8 Combustion equipment must not be located in a fire compartment that houses air-handling equipment.

Technical requirements

- 4.9 The basic technical requirements of the whole of the ventilation system should meet the relevant clauses of the Health Technical Specification. It should be noted that the Specification contains a menu of clauses that cover a wide range of applications, so it is important to select only those that are relevant to the specific application.

Note 1: At the time of writing, Health Technical Specification C04 was listed for revision in order to bring it into line with the revised standards as set out in this Scottish Health Technical Memorandum. Where conflicts in specification arise, the Scottish Health Technical Memorandum takes precedence.

- 4.10 It is essential that the main plant/ductwork is located far enough above the floor to permit the correct installation of drainage systems for cooling coils, humidifiers and heat recovery systems. Easy access for maintenance of drainage systems and their associated pipework must be provided.
- 4.11 Organic materials or substances that can support the growth of microorganisms must not be used in the construction of the plant or its distribution system. The water fittings and materials directory lists suitable materials for sealants and gaskets.
- 4.12 The plant and its distribution system must not contain any material or substance that could cause or support combustion.
- 4.13 Plants should have a high standard of air-tightness. The double-skin method of construction with insulation sandwiched between two metal faces is recommended. The panels may be available in a variety of colours at no additional cost. This can aid identification by colour coding of units in a plant room (for example green for general ventilation; blue for theatres; red for laboratories and isolation facilities; grey for extract etc).
- 4.14 The inside of the plant should be as smooth as possible. Channels, rolled angles or formed sections that could trap or hold moisture should be kept to a minimum. If stiffeners are required, they should be fitted externally. If internal bracing has to be fitted it must be of a design that will not trap or hold moisture.
- 4.15 Airflow across air treatment components such as filters, heat exchangers and humidifiers will be influenced by the pattern of the approaching airstream. If unsatisfactory conditions are created, the performance of the component will be reduced.
- 4.16 Access to items that require routine service such as filters, frost batteries and chiller batteries should be via hinged doors. The doors should be large enough (for example 500mm minimum) to allow easy access. Items requiring infrequent access such as attenuators may be via bolted-on, lift-off panels. All doors and panels should be close-fitting and without leaks.

- 4.17 Care should be taken during installation to ensure that electrical and mechanical services are not installed in positions that will reduce or impede access.
- 4.18 It can be difficult to turn off AHUs in order to inspect filters and drainage trays. Viewing ports and internal illumination will therefore facilitate routine inspection of such items. Viewing ports should be at a convenient height so that temporary ladders are not required. Internal illumination should be provided by fittings to at least IP55 rating. Fittings should be positioned so that they provide both illumination for inspection and task lighting. All of the lights in a unit should be operated by a single switch.
- 4.19 Access to AHUs and items in the distribution system such as filters or heater / chiller batteries should be via fixed ladders and platforms or pulpit-style moveable steps. The installation of distribution ductwork and other electrical or mechanical services should provide sufficient clearance to allow the pulpit steps to be easily wheeled into position.

AHU drainage system

- 4.20 All items of plant that could produce moisture must be provided with a drainage system. The system will comprise a drip tray, glass trap, air break and associated drainage pipework.
- 4.21 The drip-tray should be constructed of a corrosion-resistant material (stainless steel is preferred) and be so arranged that it will completely drain. To prevent 'pooling', it is essential that the drain connection should not have an upstand; and that a slope of approximately 1 in 20 in all directions should be incorporated to the drain outlet position. The tray must be completely accessible or, for smaller units, easily removable for inspection and cleaning.
- 4.22 Each drip tray should be provided with its own drain trap. The drain trap should be of the clear (borosilicate) glass type. This permits the colour of the water seal to be observed thus giving an early indication of corrosion, biological activity or contamination within the duct. The trap should have a means for filling and incorporate couplings to facilitate removal for cleaning. It should be located in an easily visible position where it will not be subject to casual knocks. The pipework connecting it to the drainage tray should have a continuous fall of not less than 1 in 20.
- 4.23 Traps fitted to plant located outside or in unheated plant rooms may need to be trace-heated in winter. The trace-heating must not raise the temperature of water in the trap above 5°C.
- 4.24 Water from each trap must discharge via a clear air gap of at least 15mm above the unrestricted spill-over level of either an open tundish connected to a foul drainage stack via a second trap, or a floor gully (or channel). A support should be provided to ensure that the air gap cannot be reduced. More than one drain trap may discharge into the tundish providing each has its own air break.

- 4.25 Drainage pipework may be thermoplastic, copper or stainless steel. Glass should not be used. The pipework should be a minimum diameter of 22mm and a fall of at least 1 in 60 in the direction of flow. It should be well supported and located so as not to inhibit access to the AHU.

Layout of air handling unit

- 4.26 The AHU should be arranged so that the majority of items are under positive pressure. Any item of plant requiring a drain should be on the positive pressure side of the fan. A recommended layout is given in schematic form in [Figure 3](#).
- 4.27 A separate extract unit will generally be required for the area served by each supply unit.
- 4.28 An energy recovery system will normally be fitted between the supply and extract units.

Provision of dampers

- 4.29 Fire- or smoke-actuated dampers shall be provided at the locations required by Firecode. (See [Paragraphs 5.17 - 5.21](#)).
- 4.30 Motorised low-leakage shut-off dampers should be located immediately behind the intake and discharge of each supply and extract system respectively. They should be of the opposed-blade type, opening through a full 90° and must close automatically in the event of power failure or plant shutdown to prevent any reversal of the system airflow.
- 4.31 The quality of motorised dampers is critical. They should be rigid, with square connections fitted with end and edge seals of a flexible material and with minimal play in linkages. The leakage on shut-off should be less than 2%.
- 4.32 A manually operated isolating damper should be installed between the main AHU and its distribution system to enable the unit to be isolated when cleaning is in progress.
- 4.33 Good practice will require the fitting of a main volume control damper so that the design airflow rate can be set at commissioning. The damper should be lockable in any position. If it will also be used for plant isolation, it should be capable of being reset to give the design airflow without the need for re-measurement.
- 4.34 Internal plant isolating dampers or provision for the fitting of shut-off plates between items within a unit are not required.

Vibration

- 4.35 Vibration from a remote plantroom can be transmitted by the structure of the building, may be regenerated and may sometimes be magnified many times. Units should be selected to have the minimum vibration generation and installed on suitable anti-vibration mounts. Pipe and ductwork should incorporate anti-

vibration couplings, preferably in two planes at right angles, as close to the vibration source as possible. Consideration should be given to the use of anti-vibration pipe hangers and supports.

Sequence of components

4.36 The following arrangement of plant components is typical although in many instances not all elements will be required:

- fresh air intake;
- motorised isolation damper;
- frost / fog coil;
- pre-filter;
- energy-recovery device;
- attenuator;
- fan;
- blast plate;
- attenuator;
- chiller battery;
- eliminator;
- heater battery;
- humidifier;
- final filter;
- isolation / volume control damper.

Note 2: Attenuators may be located in the intake and discharge duct if they are of a suitable type (See [Paragraphs 4.159 - 4.162](#))

There may be instances where the above arrangement is not appropriate and the plant arrangement should be planned accordingly.

Fans

General requirements

4.37 The fan should be selected for good efficiency and minimum noise level, but the overriding factor should be the selection of a fan characteristic such that the air quantity is not greatly affected by system pressure changes due to filters becoming dirty or external wind effects.

Acceptable types

- 4.38 Fans can be of the axial, centrifugal, cross-flow, mixed-flow or propeller type, depending upon the requirements of the system.
- 4.39 Where used, centrifugal fans should preferably be of the backward-blade type. Alternatively, where noise levels are more critical and pressure requirements are lower, forward-curved blade fans are acceptable. For high-power applications, aerofoil-blade fans may be appropriate.

Selection

- 4.40 Generally, large ventilation systems will use centrifugal fans due to their efficiency, non-overloading characteristics, and developed pressures.
- 4.41 Forward curved centrifugal fans can overload if allowed to handle more air than they are designed for.
- 4.42 Alternatively, it may be appropriate to use mixed flow fans in high-pressure systems.
- 4.43 Axial flow or propeller fans are generally only used in local through-the-wall systems, or systems with very low pressure requirements.
- 4.44 Cross-flow fans have very low operating efficiencies, and thus their use is restricted to applications such as fan coil units.

Location and connection

- 4.45 Fans are normally positioned to ‘blow through’ the central plant so that the cooling coil and humidifier drains will be under positive pressure.
- 4.46 The fan performance figures given by manufacturers in their catalogue data are based on tests carried out under ideal conditions, which include long uniform ducts on the fan inlet/outlet. These standard test connections are unlikely to occur in practice, the designer should therefore ensure as far as is practical that the fan performance will not be significantly de-rated by the system. This objective can be approached by ensuring that the fan inlet flow conditions comprise uniform axial flow velocities with low levels of turbulence.
- 4.47 Where the outlet duct is larger than the fan discharge connections, there should be a gradual transition, with a following section of straight duct, having a length equivalent to three duct diameters.
- 4.48 The design of the fan intake connection must be carefully considered to avoid swirl in the airstream. When the air spins in the same direction as the impeller, the performance and power consumption of the fan are reduced. When the air spins in the opposite direction to the impeller the power consumption and noise will increase with hardly any pressure increase. Airstream swirl is usually induced by large variations across the fan intake caused by the air passing round a tight bend immediately before the intake.

- 4.49 Where a centrifugal fan is located with an open intake, the clear distance between the suction opening and the nearest wall should be not less than half the diameter of the inlet. If two fans with free inlets are positioned within the same chamber, their adjacent suction openings should be at least 1 diameter apart.
- 4.50 Airtight flexible joints should be provided at fan inlet and outlet connections. They should be equal in cross-section to the points of connection and be neither longer than 200mm nor shorter than 100mm.
- 4.51 For centrifugal fans, a diffuser screen / blast plate should be fitted immediately downstream of their discharge.

Supply fan drive arrangements

- 4.52 Where the fan drive is via a motor-driven belt and pulley, it should be external to the air stream. This arrangement has the following advantages:
- the fire risk is reduced;
 - the drive is visible so it is simple to check that the belt is still there;
 - particles shed from the drive belt are outside of the air stream;
 - if the belt slips, the “burning rubber smell” is not transmitted down into occupied areas of the premises;
 - noise generated by the motor and drive will not be transmitted along the ductwork;
 - waste heat is excluded from the system;
 - the drive may be through a vee or toothed belt and pulley. The latter have the advantage of eliminating belt squeal on start up and have a longer service life. They are particularly suitable where the fan drive motor is fitted with a soft start and should be located external to the air stream.
- 4.53 The drive train should be easily visible without the need to remove access covers. Protecting the drive train with a mesh guard is the preferred option. For weatherproof units designed to be located outside, the fan drive will be external to the duct but enclosed. It should be easily visible through a viewing port with internal illumination and access via a lockable hinged door.
- 4.54 For direct-coupled fan and motor units, the motor should be out of the air stream.
- 4.55 For induction drive ‘plug’ motor arrangements (where the motor is fitted within the fan and is integral to it) and in line axial fans with a pod motor; the fan / motor combination may be within the air stream provided the motor windings are protected from over temperature by a thermister and lockout relay.

Extract fan drive arrangements

- 4.56 The preferred method where the fan drive is via a motor driven belt and pulley arrangement will be to locate it external to the air stream.
- 4.57 The fan drive and motor may be located inside the duct within the air stream provided the motor windings are protected from over-temperature by a thermister and lockout. The drive train should be easily visible through a viewing port, have internal illumination and access via a lockable hinged door.
- 4.58 Where the system air is explosive, aggressive or has high moisture content, the extract fan motor must be located outside the air stream. This is generally achieved with axial fans by using a bifurcated unit.

Control

- 4.59 Fans in healthcare applications are normally either single or two-speed. Where there is a requirement for two-speed operation, this is generally via a local user control (for example, in a hood extract system to provide a boost facility) or via a time schedule for energy saving during unoccupied periods.
- 4.60 Normally only a single motor is required with a standby motor available for fitting as necessary or fitted but not belted. Twin, run and standby motors - with the standby being jockeyed around - are not required.
- 4.61 Where there is a specified requirement for standby fans, the system should incorporate an automatic changeover facility activated via an airflow sensor. Fault indication should be provided.
- 4.62 The control of fans in terms of start-up and run is increasingly being vested in computer software. Inverter-drive, variable-speed, soft-start systems are becoming a standard approach. It should be remembered that most healthcare applications require known amounts of air to be delivered while the system is in use. Constant volume systems that deliver specified air-change rates are therefore the norm. Duct- or room-pressure-controlled, variable-speed systems have a very limited application in healthcare.
- 4.63 It is necessary to ensure that - should the computer control system or its software develop a fault - then the fan can be switched to a direct-start, fixed-speed, manual operation. This is particularly important for critical care systems serving operating suites, high-dependency care units of any type, patient isolation facilities, laboratories and pharmaceutical production suites. Off-site software support is no substitute for the ability of on site staff to override the automatic control and keep the system operating in an emergency. Under these circumstances actions that may shorten the life of the plant are considered of secondary importance to that of preserving the health and safety of patients and staff.

Heater batteries / heater coils

General requirements

- 4.64 Frost batteries are installed to protect the downstream filters from low-temperature, high-humidity intake air conditions. As they handle unfiltered air they should be constructed of plain tubing without fins and be as near to the outside as possible to minimise condensation during cold weather. Access for cleaning will need to be provided to both sides of the coil.
- 4.65 Where steam coils are used for a frost battery, they may be constructed using spiral-finned copper tube. As they will be prone to fouling the tube layout and spacing should permit easy access for regular cleaning.
- 4.66 Main and branch heater-batteries should be constructed of solid-drawn copper-tube coils with copper fins, generally connected in parallel.
- 4.67 Where there is a wet heating system in the areas served, the main heater-battery should be sized for the ventilation requirements only, and not for the fabric loss.
- 4.68 Access for cleaning must be provided to both sides of all frost batteries and heater-batteries.

Acceptable types

- 4.69 Electric, water or steam heater-batteries may be considered. However, electric heater-batteries are expensive to operate and where there are alternatives, their use should be restricted to low-power use (for example trimming control).
- 4.70 Where steam-supplied heater-batteries are used, their control, venting and trapping systems should be designed so that a vacuum cannot occur within the coil. The condensate drainage arrangements should not allow pressure to build in the main resulting in a back-up of condensate in the coil.

Location

- 4.71 Where possible, wet-trimmer heater-batteries should be located in plant areas.
- 4.72 Where it is necessary to locate heater-batteries in false ceilings etc, consideration should be given to the use of electric heaters. If this is not practicable, drip-trays should be installed under both the battery and the control valve assembly to protect the ceiling. A moisture sensor and alarm should be fitted in the tray. In any event, to facilitate maintenance access, they should be located above corridors or other non-critical areas and never above patient occupied spaces.
- 4.73 Auxiliary fan coil units should not be installed in the ceiling above an occupied space. They should be accessible for routine maintenance and cleaning without the need to cause significant disruption to the operation of the department that they serve.

Control

- 4.74 LPHW frost coils should be controlled by an off-coil temperature sensor operating a motorised valve to provide a minimum plant “on temperature” of between 2°C and 5°C. The off-coil temperature of the frost coil is generally sensed by a serpentine thermostat downstream of the coil or upstream of the next plant item. This thermostat will shut the fan down if any part of the air stream is below the minimum set-point.
- 4.75 Steam-supplied frost coils should be fitted with an on/off control operated by a temperature sensor mounted upstream of the battery. These are normally set to open the control valve fully when the outside temperature drops to +1°C. This will ensure that there is no standing condensate in the base of the coil.
- 4.76 The main heater-battery should be controlled in the same manner under the dictates of either an off-coil temperature sensor, or a room temperature sensor, depending on the plant configuration and method of control. Trimmer heater-batteries are generally controlled by one or more averaging temperature sensors within the room or rooms in the zone.
- 4.77 Heater-battery control valves should drive to a closed position on system shutdown or fan failure. The control system should then automatically set to provide frost protection.

Cooling coils

General requirements

- 4.78 Cooling coils will need to be decontaminated periodically. They must have good access both up and downstream. Hinged access doors with viewing ports and illumination inside the duct should be provided both sides of the coil.
- 4.79 An eliminator will be required downstream of all cooling coils. The eliminator may take the form of an extension of the coil fins or be a separate device. If a separate device it should be removable as a unit to permit cleaning of the coil face.
- 4.80 All cooling coils must be fitted with their own independent drainage system as specified above. A baffle or similar device must be provided in the drip tray to prevent air bypassing the coil. The tray should be large enough to capture the moisture from the eliminator, bends and headers.
- 4.81 Where coils are greater than 1m high, intermediate drip-trays will be required.

Selection

- 4.82 Cooling coils supplied with chilled water are the preferred option. For small loads or where chilled water is not available, direct expansion coils may be used.

- 4.83 Care must be taken in selection to minimise electrolytic action resulting from condensation on the airside. Coils constructed from copper tubes with copper fins extended on the downstream side in the form of an eliminator and electro-tinned after manufacture are preferred. Aluminium fins should only be used if vinyl-coated.
- 4.84 All parts of the coil and its associated ductwork in contact with moisture must be manufactured from corrosion-resistant materials. Pressed steel coil headers, even if treated, have been shown to be prone to corrosion over time and should not be used. Steel mounting frames and casings present similar problems hence stainless steel is preferred.

Location

- 4.85 Microorganisms that multiply in moisture cannot be avoided when the coil is dehumidifying. However, locating the final filter downstream of the coils will reduce the risk of infection.
- 4.86 Cooling coils in AHUs should be located upstream of the final filter.
- 4.87 Where any cooling coil has to be located above a ceiling, drip-trays should be installed under both the coil and the control valve assembly to protect the ceiling. A moisture sensor and alarm should be fitted in the tray. To facilitate maintenance access, they should be located above corridors or other non-critical areas and never above patient occupied spaces.

Control

- 4.88 There are two basic methods of control for cooling coils:
- off-coil control – used in multi-zone systems or single-zone systems where close humidity control is required, to provide a constant maximum off-plant condition which satisfies the temperature and high humidity requirements of the zone with the highest load;
 - sequential control – used in single-zone systems, or multi-zone systems with averaging sensors where close control is not required. A room or duct temperature sensor controls the cooling coil and heater battery in sequence to maintain constant room conditions.
- 4.89 The advantage of off-coil control is that accurate humidity control can be provided without relying on humidity sensors, which are prone to inaccuracy and drift. Off-coil control is however, expensive to operate in terms of energy consumption, due to the fact that there is no feedback of room loads, and thus at low loads and in systems where there are large zonal variations, significant over-cooling and reheating will occur.
- 4.90 On systems with two-speed operating, it is usual to isolate the cooling coil upon selection of low speed. In addition, on system shutdown, low airflow or fan failure, the cooling coil must be isolated.

Humidifiers

Design need

- 4.91 Humidification was originally required for some healthcare applications in order to control the risk associated with the use of flammable anaesthetic gases. The use of such gases has now ceased. Humidification is therefore no longer required unless there is a very specific application requirement.
- 4.92 Operating-theatre AHUs do not generally require humidifiers but provision for their retrofitting in terms of space provision and a capped drainage system should be provided.
- 4.93 Where humidification is required, it will be subject to the specific requirements set out below. These are intended to ensure that the unit will operate safely and not become a source of contamination.

General requirements

- 4.94 The most important requirement for a humidifier is to create complete mixing of the steam with the air. The manufacturers' instructions should be followed regarding minimum distances which should be allowed before bends or other components. This is particularly important with respect to a filter mounted downstream. If it becomes saturated by the humidifier, organisms can grow through the filter and be released into the duct. These may then be carried on the airstream into an occupied space.
- 4.95 The section of ductwork containing the humidifier may need to be periodically decontaminated. Hinged access doors with viewing ports and internal illumination should be provided. A label warning that the device emits live steam and should be isolated prior to opening should be affixed to the access door.
- 4.96 All parts of the humidifier and its associated ductwork in contact with moisture must be manufactured from corrosion-resistant materials. Stainless steel is preferred.
- 4.97 The electrodes of self-generating electrode-boiler type humidifiers should be stainless steel.
- 4.98 All humidifiers must be fitted with their own independent drainage systems as detailed in [Paragraphs 4.20 - 4.25](#) or [4.72 and 4.87](#).
- 4.99 For self- and locally-generated steam humidifiers, the cleanliness of the water supply is essential for their safe operation. Provision should be made for draining down supply pipework and break tanks for periodic disinfection and cleaning during periods when they are not required in service.
- 4.100 The addition of treatment chemicals for continuous control of water quality for humidifier/air handling units should be avoided. Consideration could be given to installing a UV system to control microbiological growth. Given the limitations of

UV systems, however, this will require filtration to high quality to ensure the effectiveness of exposure of organisms to the UV irradiation. As with all water treatment systems the unit should be of proven efficacy and incorporate UV monitors so that any loss of transmission can be detected.

Acceptable types

- 4.101 Only steam-injection manifold-type humidifiers are considered suitable for use in health building air-conditioning systems. Water humidifiers of any type should not be used.
- 4.102 Steam may be derived from the central steam supply provided that it does not contain any treatment carry-over, or generated locally either within or adjacent to the humidifier.
- 4.103 The introduction of steam should be by an appliance specially designed to discharge dry steam into the air-conditioning system without objectionable noise or carry-over of moisture.
- 4.104 During the design stage, consideration should be given to the proposed methods for the regular cleansing of the humidifier(s) and their components.

Selection

- 4.105 The number and length of steam-injection manifolds to be used is dependent on various factors such as duct cross-sectional area, air velocity, dry-bulb temperature and manifold design. Guidance from the manufacturer should be followed closely.
- 4.106 A mains steam humidifier can be noisy and will be difficult to control if it is operated at an excessive steam pressure. It should be sized for an operating pressure of approximately 1 bar. The pipework supplying it should be provided with a dirt pocket, pressure reducing valve and steam trap installed as close as practicable to the humidifier, so that the steam condition at entry is as dry as possible. A temperature switch on the condensate line (or equivalent design provision by the humidifier manufacturer) should be incorporated to prevent 'spitting' on start-up.
- 4.107 Most operational problems with mains steam humidifiers arise because of back-pressure in the condensate discharge line which will result in flooding into the duct. Unless the condensate from the device can be discharged and collected at atmospheric pressure, it should be discharged directly to drain.
- 4.108 A local steam generator, where used, must be fed with potable quality water. Additional water treatment to the standard set out above may be required. If the humidifier is unused for a period exceeding 48 hours, it must automatically drain its water content, including that contained in the supply pipework, right back to the running main and leave itself empty.
- 4.109 Some steam generators are of a type that requires regular cleaning and descaling. The design must allow for them to be installed such that they can be

physically isolated from the air duct in order to prevent contamination of the supply by cleaning agents while this is taking place.

Location

- 4.110 Careful siting of the humidifier injection manifold is required to prevent the steam impinging onto the side(s) of the duct, condensing and generating excess moisture.

Control

- 4.111 Accurate humidity control can only be provided on single-zone systems, or multi-zone systems with zonal humidifiers. In the above systems, humidity sensors control the humidifier for low-level humidity control, and override the temperature controls to open the cooling coil valve for high-limit humidity control.
- 4.112 Multi-zone systems are more usually controlled by a minimum humidity sensor located in the supply duct(s) following the last heater-battery.
- 4.113 Overriding controls separate from the normal plant humidistat should be installed. Their purpose is to prevent excessive condensation in the conditioned space when starting up. A time delay should be incorporated into the humidifier control system such that the humidifier does not start until 30 minutes after the ventilation/plant start-up. In addition, a high-limit humidistat should be installed to limit the output of the humidifier so that the saturation in the duct does not exceed 70%. This humidistat is to control the added moisture. It is not necessary to install a de-humidifier to reduce the humidity of the incoming air if it already exceeds 70%. The humidifier control system should ensure that the humidifier is switched off when the fan is not running.
- 4.114 On systems with two-speed operating, it is usual to isolate the humidifier upon selection of low speed. In addition, on system shutdown, low airflow or fan failure, the humidifier should be isolated.

Filtration

General requirements

- 4.115 The purpose of filtration is to reduce the level of airborne contamination in an air stream. It is generally carried out in stages.
- 4.116 Filters must be securely housed and sealed in well-fitting frames that minimise air by pass. Air by pass significantly reduces filter efficiency, the higher the filter grade the greater the effect. Mounting frames should be designed so that the air flow pushes the filter into its housing to help minimise air bypass. Mounting frames that withdraw so that the filter can be changed without having to reach into the unit are preferred.

- 4.117 Neither the filter media, nor any material used in the construction of the filters, should be capable of sustaining combustion. The filter media should be such that particles of it do not detach and become carried away by the airflow.
- 4.118 Filters need to be readily accessible for replacement so a hinged access door should be provided. The upstream side of the filter should be visible for inspection through a viewing port with internal illumination.
- 4.119 All filters should be provided with a means of visually checking the differential pressure across them. Direct-reading dial-type gauges marked with clean and dirty sectors are preferred.
- 4.120 A complete spare set of filters must be provided at handover.

Definition of filter terms

- 4.121 Particulate air filters are divided into four categories:
 - general ventilation filters grades G1 to G4;
 - fine filters grades F5 to F9;
 - high efficiency particulate filters (HEPA) graded H10 to H14;
 - ultra-low particulate air filters (ULPA) graded U15 to U17.
- 4.122 General filters are graded in terms of their ‘Synthetic dust weight ‘Arrestance’’. This represents the percentage of a test dust captured by a filter. ‘Arrestance’ provides a good indication of a filter’s ability to remove the larger, heavier particles found in outdoor air. These are of a size to block finned batteries and large enough to settle out in the air distribution system.

BSEN 779 grade (Eurovent grade)	% Arrestance	Notes and typical healthcare application
G1 - (EU1)	< 65	Metal mesh grease filter
G2 - (EU2)	65 to < 80	Coarse primary filter
G3 - (EU3)	80 to < 90	Primary air intake; return air; energy recovery device protection
G4 - (EU4)	> 90	General purpose tempered air supply

Table 4: General Filters

- 4.123 Fine filters are graded in terms of their ‘Atmospheric dust spot Efficiency’’. This is a measure of the filter’s ability to remove the very fine staining particles found in outdoor air. It will indicate how ‘visibly’ clean a filter will keep a ventilated space. The staining particles are approximately the same size as most common bacteria so it is also a rough measure of the filter’s ability to remove microorganisms.

BS EN 779 grade (Eurovent grade)	% Efficiency	Notes and typical healthcare applications
F5 - (EU5)	40 to 60	General purpose panel / bag filter
F6 - (EU6)	60 to < 80	Basic grade bag filter
F7 - (EU7)	80 to < 90	Medium grade bag or pleated paper Conventional operating theatre supply air
F8 - (EU8)	90 to < 95	High grade bag or pleated paper
F9 - (EU9)	> 95	Basic HEPA filter – Level 8 clean rooms

Table 5: Fine Filters

- 4.124 High efficiency filters (HEPA and ULPA) are graded in terms of their ability to capture their 'Most Penetrating Particle Size' (MPPS). High-efficiency filters self-select the particle that they are least able to trap, hence the MPPS. They are then tested against that size of particle. These filters are designed to provide very high-efficiency filtration of particles in the sub-micron size range.

BS EN 1822 grade (Eurovent grade)	% Efficiency @ MPPS	Notes and typical healthcare application
H10 - (EU10)	85	Ultra-clean theatre terminal
H11 - (EU11)	95	
H12 - (EU12)	99.5	
H13 - (EU13)	99.95	
H14 - (EU14)	99.995	Pharmacy aseptic suite Category 3 room extract
U15 – U17	-	Not generally used in healthcare

Table 6: High Efficiency (HEPA) Particulate Filters

Selection primary filters

- 4.125 All filters should be of the dry type. Panel filters are cheap and disposable with relatively low dust-holding capacity. They are generally used as pre-filters to eliminate large particles that would otherwise clog or cause damage to the fan and finned heating and cooling batteries. Stainless steel frames that hold disposable pre-cut filter pads are preferred.
- 4.126 General ventilation supply plant should incorporate primary air filters of grade G3, sized for a maximum face velocity of 2.0 m/s. Additional coarse pre-filters may be justified where the intake air is exceptionally polluted. They are sometimes fitted as a temporary measure when building work is being carried out in the vicinity of the air intake.

Secondary filters

- 4.127 Where a higher standard of filtration is required, secondary bag or pleated paper panel filters would be used. Rigid frame filters incorporating pleated paper elements are preferred over bag filters for critical care applications such as operating theatres.

- 4.128 In urban or other areas of high atmospheric pollution, a higher standard of filtration may be justified to reduce the level of staining to internal finishes.

Extract air filters

- 4.129 Extract filtration will generally only be required where heat-recovery devices are installed. There are a very limited number of specialised applications (microbiological safety cabinets and similar LEV systems) where contaminated air is required to be filtered prior to discharge to atmosphere. If it is safe for staff to work in a room without wearing respiratory protective equipment, it is safe to discharge the room air to atmosphere without filtration.

Return-air filters

- 4.130 They are used to reduce the load on HEPA filters in recirculating applications such as Ultra Clean operating suite ventilation canopies and pharmacy aseptic suites.

High-efficiency filters – HEPA and ULPA

- 4.131 HEPA filters are expensive so their use should be kept to a minimum. Applications requiring HEPA filters include the air supply to aseptic suites in manufacturing pharmacies, the discharges from microbiological safety cabinets and isolation facilities.
- 4.132 If used, HEPA filters should be of the replaceable panel type with leak-proof seals. They should be installed in a manner that permits on-site validation of the filter and its housing. This may involve the release of a Dispersed Oil Particle (DOP) challenge smoke through an injection point upstream of the filter and a measurement of the DOP penetration across the downstream face. Alternatively a particle-counting method may be used.
- 4.133 HEPA filters are sometimes fitted in extract systems to capture hazardous substances or organisms. Design provision must be made for the subsequent safe handling of contaminated filters by maintenance staff. This may be achieved by:
- sealing the hazardous substance into the filter before it is removed;
 - providing a system to fumigate the filter to kill any organisms;
 - housing it in a "safe change" unit that permits the filter to be ejected into a bag and sealed without staff having to come into direct contact with it.
- 4.134 In view of the costs and problems associated with placing HEPA filters in extracts, it is recommended that a full risk assessment be carried out at the design stage. This should include defining the true need for HEPA filters in an extract; validation of its performance at installation; the method of safely changing a contaminated filter; and its subsequent disposal.

- 4.135 ULPA filters are very expensive and are designed to remove particles below a size that are either surgically or aerobiologically significant. There would have to be exceptional circumstances in order to justify their use in healthcare ventilation systems.

Activated carbon filters

- 4.136 Activated carbon filters are able to remove gases and vapours from an air stream and are graded according to the range of substances they can remove. They are not normally fitted in air-conditioning supply systems.
- 4.137 They are occasionally fitted retrospectively because the main air intake has been poorly sited and is drawing in traffic fumes. Where used they must be protected by a particulate air filter.
- 4.138 Activated carbon filters are more commonly used in specialised fume extraction systems when the location of the discharge means that dilution cannot be relied upon to disperse noxious fumes.

Location

- 4.139 The primary filter should be positioned on the inlet side of the supply fan, downstream of the frost coil. The secondary filter, when fitted, should be on the positive-pressure side of the fan. This will prevent air being drawn into the system after the filter and capture any particles shed by items of equipment within the AHU.
- 4.140 The filter installation must be arranged to provide easy access to filter media for cleaning, removal or replacement, with side or front withdrawal as required.

Control

- 4.141 Differential-pressure transducers should be provided to monitor and alarm remotely on excessive filter pressure drop. In critical areas dirty-filter indication lights should be provided at the point of use.

Energy-recovery

General requirements

- 4.142 Energy recovery will normally be fitted to all healthcare ventilation systems. It may be omitted only where it would clearly be uneconomic. Where the economic case is marginal, space should be allowed for the retrofitting of an energy recovery system.
- 4.143 For systems in healthcare premises, a plate heat exchanger or 'run-around coil' system is suitable. Thermal wheels may be used providing they are fitted with a purge sector. The small amounts of air leakage across those devices are not considered significant. Other systems such as heat pumps or heat pipes are

also suitable. Selection should be based on relative locations of the supply and extract units, ease of maintenance and practicality. Cleaning access will be required to both sides of any energy-recovery device.

4.144 The following are the minimum energy transfer efficiencies required for devices handling equal air volumes:

- run-around coil – 45%;
- plate heat exchanger – 50%;
- thermal wheel – 65%;
- any other energy-recovery device – 50%.

4.145 If a plate heat exchanger is chosen, the plates should be constructed of metal. Plastic should not be used for internal bypass dampers and drive gears.

4.146 Whichever energy-recovery device is chosen the extract side will need to be protected by a G3 filter and provided with a drainage system as described in [Paragraphs 4.20 - 4.25](#), to remove condensate.

Location

4.147 Energy-recovery devices should be located downstream of the frost battery and pre-filter, prior to the cooling coil or main heater battery on the supply side.

Control

4.148 It is essential to consider the control of both the energy recovery device and the frost battery when assessing the economics of recovery, as all energy provided by the frost battery will directly reduce the heat exchange of the recovery device. To this end, the off-coil setting of the frost coil should be the minimum possible to protect the primary filter (for example +2°C).

4.149 The energy-recovery device should be controlled in sequence with the main heater battery, and should incorporate a control to prevent the transfer of unwanted heat when the air-on condition rises above the required plant set point.

4.150 In instances where the plant is cooling the air, it may be possible to remove heat from the supply air at high ambient conditions, under the dictates of enthalpy sensors in the intake and extract ducts.

Attenuation

General requirements

4.151 Noise will be generated in an air distribution system by the fan, plant items and airflow. The ductwork is a very effective transmitter of this noise hence there is generally a need to limit the noise transmission to meet the requirements of the

building. This normally involves the provision of sound attenuation treatment as part of the overall ductwork system design.

- 4.152 A thorough assessment of the design should be made to assess the noise impact. This should take into account the following primary factors:
- fan- and plant-noise generation;
 - air-flow generated noise in ductwork fittings and dampers;
 - noise generated at grilles, diffusers and other terminals;
 - noise break-in and break-out of ductwork;
 - cross-talk and similar interference;
 - the noise limitations for the building and surrounding areas;
 - external noise generation.
- 4.153 A method of assessment of these factors and the sound attenuation requirements of ductwork systems is given in CIBSE Guide B.
- 4.154 The fan is usually the main source of system noise. The sound power that it generates varies as the square of the fan pressure, and thus to limit the fan noise level the system resistance should be kept as low as economically possible. As a general rule the selected fan should operate close to its point of maximum efficiency to minimise its noise generation. Where there is disturbance to the airflow at the fan inlet, the manufacturer's stated fan noise levels should be increased by up to 5 dB(A). More precise guidance on this aspect may be available from the manufacturers.
- 4.155 Fans radiate noise through both the inlet and outlet connections and it may be necessary to provide attenuation to limit the noise from both of these connections. It is always preferable and more economic to control noise and vibration at source, or as close to source as possible. It should be noted that attenuators offer a resistance to airflow. The resistance must be included in the fan and ductwork calculations.
- 4.156 Provided care is taken in the design and construction of low-pressure systems to avoid significant noise generation in the ductwork, attenuation should only be needed to absorb fan noise.
- 4.157 Noise breakout from all equipment housed in the plantroom must be taken into consideration if control is to be satisfactory. Any ductwork within the plantroom after the silencer should be acoustically insulated to prevent noise break-in or the silencer relocated at the point of entry or exit of ductwork to and from the plant room.
- 4.158 There is no complete means of control over external noise generation from such as road traffic, aircraft, factory and community noise. Consideration must be given to this at the design and planning stage.

Acceptable types and location

- 4.159 The noise levels produced by ventilation and other plant should be reduced by either lining the inside of the duct with sound-absorbing material or fitting bespoke attenuator units.
- 4.160 In supply systems, sound-absorbing material should not be applied to the inside surface of a duct system downstream of the final filter, owing to the risk of mechanical damage and the subsequent dispersal of the media into the ventilation system.
- 4.161 In supply and extract systems, sound-absorbing material must not be applied to the inside of a duct within 1 metre of a fire damper. The material should be non-particle-shedding and fire-resistant (further guidance can be found in SHTM Firecode suite of documents). Where sound-absorbing material is applied in a section of duct that will be routinely exposed during maintenance activities it should be protected from mechanical damage.
- 4.162 Bespoke attenuator units with a sound-absorbing infill suitable for the quality of air being handled and protected by a perforated sheet metal casing are the preferred option for critical systems. Absorption of moisture, dirt and corrosive substances into the 'in-fill' and the release of fibrous particles into the airstream should be prevented by the use of a membrane. The membrane material should have a declared service life of at least 25 years. If these conditions can be met then the attenuator may be located in the supply ductwork downstream of the final filter. When so located, cleaning access should be provided at both ends of the attenuator unit.

5. Air distribution system

Air distribution arrangements

Ductwork distribution systems

- 5.1 Ductwork systems for ventilating and air-conditioning applications are referred to by their velocity or pressure category, that is, as low, medium or high velocity (or pressure) systems. Heating & Ventilating Contractors Association (HVCA) limits are up to 10 m/s or 1,000 Pa; 20 m/s or 1,750 Pa; and 40 m/s or 3,250 Pa in the case of conventional low, medium and high pressure systems respectively. High-pressure systems are disappearing because of the constraints of the Building Regulations but existing systems may sometimes need to be altered or extended.
- 5.2 For normal applications in healthcare buildings, low velocity systems are recommended. The use of higher velocities than those recommended is not likely to be economical. Future trends are likely to be towards even lower optimum duct velocities; however, velocities below 2 m/s are unlikely to be justified.
- 5.3 The site will often dictate the main routing of ductwork systems, but in general, the design should seek to make the layout as symmetrical as possible; that is, the pressure loss in each branch should be as nearly equal as possible. This will aid regulation and may reduce the number and variety of duct fittings that are needed.
- 5.4 Main distribution ductwork should not be routed above sleeping areas. Where there is no alternative route, additional acoustic insulation will be required.
- 5.5 Where auxiliary cooling units, fans, filters or trimming devices are installed in the distribution system, they must be independently supported and fitted with a suitable drainage system where appropriate. If they are a source of vibration they should be linked to the distribution ductwork via flexible connections.
- 5.6 The fan of a Local Exhaust Ventilation (LEV) system provided under the COSHH Regulations should be located outside of the building so that all of the ductwork within the building is under negative pressure. Where the fan has to be within the building it should be located as close as practicable to the outside with an absolute minimum run of discharge ductwork within the building. The discharge ductwork within the building will be under positive pressure so it must not be penetrated by test holes or inspection hatches.

Ductwork materials and construction

- 5.7 The choice of duct material should take account of the nature of the air or gas being conveyed and the environment in which the duct will be placed.

- 5.8 Galvanised-sheet-steel is generally suitable and most economical for normal ventilating and air-conditioning applications. Its inherent mechanical strength renders it resistant to casual damage both during the construction phase and throughout its service life when mechanical and electrical services around it are altered. It also readily withstands the impacts sustained when rotary equipment is used to for internal cleaning.
- 5.9 In instances where moisture levels and/or corrosive elements in the air being conveyed are very high, aluminium, stainless steel, PVC or GRP (glass-reinforced plastic) ducts should be used. Stainless or black steel are the only suitable materials for high-temperature ductwork.
- 5.10 In inherently wet areas, such as the base of fresh air inlet ducts and some extract systems, the ductwork may require draining to prevent a build-up of standing water. The layout of the drains should be as specified in [Paragraphs 4.20 - 4.25](#).
- 5.11 Where builderwork plenum chambers or ducts are used, these may be constructed of various materials. However all such ducts must be rendered and sealed to prevent dust shedding. A greater allowance may need to be made for leakage.
- 5.12 Galvanised, black and stainless steel ductwork should be manufactured and installed to the current HVCA specification for sheet metal ductwork DW144, but excluding the use of bolt-through supports.
- 5.13 GRP and PVC ductwork should be manufactured and installed to the current HVCA specification for plastic ductwork DW154.
- 5.14 Where phenolic-board ductwork is considered, care should be taken to ensure that it is fabricated to a quality standard and installed strictly in accordance with the manufacturers' instructions. Its pressure rating and degree of support should be suitable for the application and ducts should be fitted with mechanical protection where required. Designers should be fully conversant with installation techniques and Installers should be experienced having received training in the techniques required and certified to this effect by the manufacturers. Due consideration should be given to the impact on ductwork pressures created by the closing of dampers. Phenolic-board ducting should not be installed in plant rooms or any other areas where it could be vulnerable to impact damage. Internal cleaning using mechanical (rotary) means is also liable to cause damage to the integrity of surfaces.
- 5.15 Flexible ductwork is unsuitable for air distribution in healthcare applications. It should only be used to make the final connection to a terminal (See [Paragraphs 5.54 and 5.55](#)).
- 5.16 The inside of the ductwork should be free from structural projections and as smooth as possible. Flanged, gasketed joints are preferred.

Fire aspects, damper types and locations

- 5.17 It is essential that all relevant fire aspects of ducting systems are agreed with the fire officer before the design is finalised.
- 5.18 Ductwork must be fire-stopped where it penetrates fire compartment walls, floors and enclosures, cavity barriers and sub-compartment walls or enclosures, and provided with weatherproof collars where roofs or external walls are penetrated.
- 5.19 Fire/smoke dampers shall be provided at the locations required by SHTM Firecode. The fire-damper mounting frame must be securely attached to the building fabric. Where a fire-damper is not mounted directly in a fire compartment wall, it must be correctly supported and the ductwork between it and the firewall must possess the same fire rating as the firewall that it penetrates. The fire-rated portion of ductwork must not be penetrated by test holes or inspection hatches. All fire/smoke dampers shall be capable of remote re-setting via the Building and Energy Management System (BEMS) or equivalent, after periodic testing procedures.
- 5.20 An access hatch shall be provided adjacent to each fire damper so that its correct operation can be directly observed.
- 5.21 Smoke-diverting dampers must be provided on recirculation air systems to divert automatically any smoke-contaminated return air to the outside of the building in the event of a fire; and arranged so that the normally open smoke-diverting damper on the return-air branch to the input unit closes and all the return air is exhausted through the extract fan. Guidance is available in SHTM 81 and BS5588: Part 9.

Duct sections

- 5.22 Ducting is generally available in rectangular, circular and flat oval sections, although other sections may be made for special situations.
- 5.23 Rectangular ducting is most common on low-pressure systems, for the following reasons:
- it can readily be adapted to fit into the space available;
 - fittings are cheaper than those for circular or flat oval ductwork;
 - it can readily be joined to such component items as heating and cooling coils, and filters.
- 5.24 When sizing ductwork, the designer should take into account:
- both installation and operating costs;
 - space limitations imposed by the structure and other services;
 - operating noise levels;

- requirements of regulation at the commissioning stage.
- 5.25 For overall economy and performance, the aspect ratio should be close to 1:1, since high aspect ratios increase the pressure loss, heat gains or losses and overall cost (for example, changing the aspect ratio from 1:1 to 1:4 can typically increase the installed cost of the ductwork by 40% and add 25% to the heat gains or losses).
- 5.26 Rectangular ducting should not be the first choice for high pressure systems, and should be avoided in systems operating at high negative pressures, because the strengthening of the flat sides and the sealing requirements necessary to make rectangular ducts suitable for these high pressures are costly.
- 5.27 Circular ducting is preferable for high-pressure systems, and for systems operating at high negative pressures. In the case of the latter, additional stiffening rings may be necessary. Machine-formed spirally-wound ducting and a standard range of pressed and fabricated fittings can sometimes make circular ducting more economical, particularly in low pressure systems having a relatively low proportion of fittings.
- 5.28 Flat oval ducting provides an alternative to circular ducting, principally where there is a limitation on one of the dimensions in the space available for the duct run.
- 5.29 Other sections may be used, such as triangular sections to pass through roof trusses. Such sections present difficulties in the provision of fittings, and connections to standard plant items, and are likely to be more expensive than traditional sections.

Standard ductwork fittings

- 5.30 All fittings should conform to current HVCA specification DW144. Wherever possible, long radius bends, large radius main branches, not more than 45° angle sub-branches and long-taper transformations should be used.
- 5.31 Fittings should be arranged with vanes in sub-branches connected directly to grilles and diffusers, and turning vanes in square bends (when used). When vanes are used, additional cleaning access will be required.
- 5.32 The number of duct fittings should be kept to a minimum and there should be a conscious attempt to achieve some standardisation of types and sizes. Increasing the number and variety of fittings in a system can markedly raise its overall cost.
- 5.33 Bad design in relation to air flow can lead to vibration of flat duct surfaces, increases duct-generated noise and pressure loss, unpredictable behaviour in branch fittings and terminals, and adverse effects on the performance of installed plant items (such as trimmer batteries).

Branches

- 5.34 There are many designs of branches and junctions in use. The important features are that the flow should be divided (or combined) with the minimum interference and disturbance. Changes in duct sizes should not be made at the branch but a short distance downstream (or upstream). A good dividing branch design cannot be effective if the flow entering the branch is not uniform across the section.

Changes of section

- 5.35 The expansion of a duct section should be formed with sides having a total included angle of no more than 30° , and preferably less than 20° . If the angle of expansion is greater, the flow is not likely to remain attached to the walls of the duct and large eddies will be formed with flow reversal at the walls. This leads not only to a high-pressure loss, but also to non-uniform velocity pattern at the outlet. Where there is insufficient space for a gentle expansion and a greater angle is necessary, internal splitters should be used.
- 5.36 A contraction in a duct section is less critical, but the total included angle of the taper should not exceed 40° (or 20° where the contraction is made on one side of the duct only)
- 5.37 The most economical way to change the section of a rectangular duct is to restrict the change of duct size to one side only. If the calculated reduction or increase to the side dimension is 50mm or less, it is usually not economical to change the size at the position. The minimum size of a rectangular duct should usually be 150mm x 100mm.

Other fittings

- 5.38 As a general rule, fittings should avoid abrupt changes in direction and also sharp edges that cause the flow to separate and form eddies, thus limiting pressure loss and causing noise generation. If the fitting leads to the flow preferentially attaching to one side of the outlet, then a significant length of straight downstream duct is necessary before the next branch or fitting; this length should be greater than five equivalent diameters.

Thermal insulation

- 5.39 Thermal insulation is applied to ductwork to reduce heat exchange, and to prevent condensation.
- 5.40 In a duct system, the air temperature changes can be significant, especially when passing through untreated space, and these have the effect of reducing the heating or cooling capacity of the air and of increasing the energy input to the system. The heat transmission to and from the surrounding space can be reduced by effective insulation of the ducts.
- 5.41 Condensation can arise in ductwork systems conveying cooled air and, apart

from creating conditions conducive to corrosion of ductwork, condensation affects the heat and vapour-resisting properties of insulating materials themselves which may induce further condensation.

- 5.42 In normal circumstances, the insulation thickness for heat resistance is sufficient to prevent surface condensation, but in extreme conditions the insulation thickness for vapour resistance may be greater than that for heat resistance. When cold ducts pass through areas of high dew-point, carefully selected vapour barriers should be applied externally to the insulation.

Noise generation within the ductwork

- 5.43 Noise is generated in ductwork at sharp edges, by tie rods, damper blades, duct obstructions and sharp bends etc. This air-flow-generated noise becomes an important factor if it is about the same or greater level than the upstream noise level. (Air-flow-generated noise is often referred to as “regenerated noise”).
- 5.44 The noise level generated by airflow in ductwork is very sensitive to the velocity. The sound power of this noise is approximately proportional to the sixth power of the velocity; that is, a doubling of the duct velocity will increase the sound power by a factor of 64. The duct velocities should therefore be kept as low as possible. In general, duct fittings that have lower pressure loss factors in similar flow conditions will generate less noise.
- 5.45 Ductwork serving quiet areas should not be routed through noisy areas where noise break-in can occur and increase the noise level in the ductwork.
- 5.46 Grille, register and louvre noise should be kept to the minimum by selecting types having low noise-producing characteristics, without high tonal noise, and should be fitted with acoustically treated external inlet and outlet louvres.
- 5.47 Cross-talk attenuators may be necessary where noise intrusion between adjacent spaces can arise and where individual room confidentiality is required. They will normally be of the ‘through-the-ceiling, ‘up-and-over’ type and may include a fire damper if required.

Volume control damper locations

- 5.48 Manually operated balancing dampers are needed generally:
- in the main duct downstream of the fan;
 - in branches of zone ducts;
 - in sub-branch ducts serving four or more terminals;
 - at terminals not covered by the previous item.
- 5.49 Dampers integral with terminals should only be used for final trimming of air volumes, otherwise noise and air distribution problems may ensue.
- 5.50 Dampers in rectangular ducts should be single-bladed when the longer side is up to 450mm but be of the opposed-blade multi-leaf type above this size. In

circular ducts, iris-type dampers are recommended. Dampers must be accessible, incorporate a position indicator and means of locking in the commissioned position. Dampers should be located as far away as possible from adjacent branches or plant items.

Cleaning and access door locations

- 5.51 Cleaning and access doors are required to facilitate access to plant items and ductwork components for inspection, maintenance, cleaning and replacement, and must be of sufficient size to permit safe access for the required functions. Consideration should also be given to the number of doors to be provided.
- 5.52 Recommended locations for access doors are given in the current HVCA specification DW144 and are generally provided to give access to:
- every regulating damper;
 - every fire and motorised damper;
 - filter (to facilitate filter withdrawal);
 - both sides of cooling/heating coils;
 - humidifiers;
 - fans; and
 - motors and impellers.
- 5.53 Care should be taken when siting access doors to ensure that no other services to be installed will prevent reasonable access.

Flexible ducting

- 5.54 Flexible ductwork may be used for final connections to grilles and diffusers provided it is constructed to meet the fire precautions recommended in BS8313. It must not pass through fire compartment walls, floors or enclosures of sub-compartment walls or enclosures, or through cavity barriers.
- 5.55 Flexible ducting will cause a significant frictional loss and may be difficult to clean and should never be used in lieu of a bend. Where installed it should take the most direct route and be as short as possible, never exceeding 1 metre in length.

Diffuser and grille selection and sizing

- 5.56 The effectiveness of all ventilation and air-conditioning systems depends on the methods by which air is introduced to, and vitiated air is removed from, the space. The usual results of poor air-terminal selection and/or positioning are: draughts, stagnation, poor air quality, large temperature gradients and excessive noise.

- 5.57 Air can be supplied to a space in a number of ways, although any device can be broadly placed into one of two categories: that producing a diffused supply, or that producing a perpendicular jet. Diffusers may be radial or linear, and normally utilise the Coanda effect (that is, adhesion of the air stream to an adjacent surface), to reduce the risk of excessive room-air movement. A perpendicular jet is formed by discharging air through grilles, louvres or nozzles, which are generally adjustable.
- 5.58 Air-flow patterns produced by both types of terminal are dependent to a large extent on the presence of the Coanda effect.
- 5.59 Supply air terminals can be incorporated into any room surface, for example, floors, walls (high or low level), desktop etc.
- 5.60 As they operate on the jet principle, the use of sidewall and linear grilles is restricted to areas where air change rates are low, that is, less than 10 per hour. Perforated rectangular diffusers can provide acceptable conditions within the occupied zone at up to 15 air changes per hour. In areas where a higher air change rate is required, square or circular ceiling mounted diffusers should be used.
- 5.61 The performance of supply air terminal devices is provided, based on three criteria: throw, spread and drop.
- **throw** is defined as perpendicular or parallel distance from the terminal to the point at which the air velocity is 0.5 m/s isovel;
 - **spread** is defined as the width of the 0.5 m/s isovel; and
 - **drop** is defined as the vertical distance from the centre line of the terminal to the bottom edge of the 0.25 m/s isovel.
- 5.62 It is necessary to consider each of these parameters in both summer and winter conditions to ensure satisfactory operation of the air-terminal device, as warm jets behave very differently from cold jets.
- 5.63 A warm jet tends to rise until it attaches itself to a horizontal surface, while a cold jet falls. Care must be taken to ensure that this does not lead to unacceptable temperature gradients in winter or excessive air velocities in the occupied zone in summer.
- 5.64 In order to ensure satisfactory air movement within a space, it is necessary to consider interaction between air movement from adjacent terminals, and ceiling mounted fixtures (light fittings etc), as well as interaction between air movement and room surfaces.
- 5.65 If the supply and extract terminals are too close, short-circuiting may occur, while if they are too far apart, stagnant zones may be formed. Where two opposing air streams meet, the individual velocities must not be greater than 0.25 m/s.
- 5.66 Supply and extract grilles and diffusers should be fitted with opposed-blade dampers for fine balancing purposes.

- 5.67 Further guidance on the selection of grilles and diffusers is given in the CIBSE Guide B.
- 5.68 In operating theatres, the supply terminals must be able to produce a down-flow movement of air in the operating zone 1 metre above floor level. Ceiling mounted diffusers with fixed directional vanes that provide a downward turbulent airflow are the preferred option. Plenum boxes fitted with perforated screens to produce a parallel downward flow are also acceptable. Nozzles or jets of any type are not acceptable. Sidewall-mounted linear diffusers that utilise the Coanda effect to send air across the ceiling and ‘drop’ it into the operating zone are also not suitable. However linear ceiling mounted diffusers that provide a direct downward airflow around the operating zone may be used.

Transfer grille - size and location

- 5.69 Air-transfer grilles in walls, partitions or doors form an integral part of the building’s air distribution system. Modern doorsets have very low leakage rates so cannot be relied upon to permit even quite small airflows. Failure to make adequate provision for air to move from room to room will result in excessive pressure differentials and ‘door whistle’.
- 5.70 Transfer grilles are required in locations where there is a significant imbalance between the supply and extract rates in a room. They will relieve any pressure differentials that may affect the operation of the spaces and/or the ventilation system and permit airflow in a known direction. However, transfer grilles are vulnerable to damage and, in many instances, as long as the equivalent free area is provided, they can be substituted with undercut door.
- 5.71 Care needs to be taken to ensure that the positioning of transfer grilles does not interfere with the fire or smoke integrity of the building. In general, the air-transfer grilles should not be installed within fire-resisting boundaries, although if this is unavoidable, they should be fitted with fire- or smoke-dampers.
- 5.72 Where installed, transfer grilles should be of the non-vision type, sized for a maximum face velocity of 1.5 m/s.
- 5.73 In photographic dark rooms, lightproof transfer grilles will be required.
- 5.74 Cross-talk attenuators may be necessary where noise intrusion between adjacent spaces can arise and where individual room confidentiality is required. (See also [Paragraphs 5.43 - 5.47](#)).

Pressure stabilisers - size and location

- 5.75 Pressure stabilisers are required in lieu of air-transfer grilles in areas where it is necessary to maintain pressure differentials between adjacent rooms to prevent reversal of airflows for example, in operating suites, isolation facilities and clean rooms. (See also [Paragraphs 7.24 - 7.28](#)).
- 5.76 Fire precautions for pressure stabilisers are the same as for transfer grilles. For sizing criteria, refer to [Paragraph 7.23](#)

- 5.77 Pressure stabilisers should be of the balanced-blade type, with the facility to make fine adjustment of the pressure setting. They should be silent in operation and give a seal as tight as practicable when closed. The materials of construction and method of assembly should allow for cleaning and disinfection.
- 5.78 Pressure stabilisers should be installed in a visible location so that their operation can be readily observed.
- 5.79 Cross-talk attenuators may be necessary where noise intrusion between adjacent spaces can arise and where confidentiality is required. In these cases, the pressure stabiliser and cross-talk attenuator should be mounted in a short length of ductwork within the ceiling void.
- 5.80 Pressure stabilisers may need to be fitted with a stand-off baffle on their discharge side to prevent a sight line in situations where a laser will be used. Baffles may also be required to preserve privacy or prevent discharge air causing draughts or disturbing the air distribution pattern in the adjoining room. They are also useful in low-level locations to prevent the airflow path being obstructed by portable equipment.

6. Automatic controls

- 6.1 Various options for control of single and multi-zone air-conditioning systems are given in CIBSE Guide B.

General requirements

- 6.2 The basic requirements for an automatic control system are as follows:

- facilities to start, set-back and stop the plant;
- facilities to control the volumetric air-flow;
- facilities to control the system or room pressure;
- temperature control and indication;
- humidity control and indication;
- devices to monitor and indicate the plant's operating state;
- alarms to indicate plant failure, low air-flow, and filter state.

The control functions actually provided will depend on the purpose of the ventilation system.

- 6.3 There will also be a need to determine the control strategy in the event of a fire either within the zone being served or within an adjoining zone.
- 6.4 The designer should consider whether it is necessary for the supply and extract fans to be interlocked, either so that the supply fan will not operate unless air-flow is established within the extract system, or vice-versa depending on the required pressures within the rooms being served.
- 6.5 The sequence switching of units in order to prevent transient reverse airflows will be particularly important in laboratory and pharmacy areas that also contain fume cupboards, safety cabinets and other LEV systems.
- 6.6 Alarms should be provided to show 'filter fault' and 'low air-flow'. The "filter fault" alarm should be initiated by a predetermined increase of pressure differentials across the filter. The 'low air-flow' alarm should be initiated when the supply air quantity falls to 80% of the design value.

Objectives of control system

- 6.7 The primary objective of ventilation plant control system is to maintain the space served within the required environmental control limits, at the appropriate times, regardless of external conditions or internal loads and with the minimum energy consumption.

- 6.8 Often, it is not possible to predict accurately building load variation at the design stage, and thus optimum set points cannot be assessed. Information provided by monitoring the operation of the plant via a Building and Energy Management System (BEMS) will enable optimum set points to be established and energy consumption reduced. Control of most systems will be via a BEMS. This will enable the operating conditions and control tolerances to be set and monitored. The BEMS may also be set to log the actual energy consumed by the system together with that recovered by the energy-recovery device. This will provide a useful check on overall operating efficiency and provide evidence that energy targets are being achieved.
- 6.9 BEMS incorporating self-adaptive control algorithms that automatically adjust the set-point to the suit the usage and load are preferred. The provision of movement sensors within the controlled space in order to determine the actual occupancy will facilitate this process.
- 6.10 The failure of specialised ventilation systems can have grave consequences for the delivery of healthcare. Control systems should therefore be simple, robust and reliable.
- 6.11 Computer-software-driven control systems are becoming the norm in building services. However, it should be remembered that healthcare ventilation systems need to be available to operate outside of normal working periods when software support is not available. Should the software fail, it will be left to site staff, who may have little knowledge of the control algorithms to restart the ventilation system. It is therefore essential to ensure that a simple means of re-starting critical systems in the event of a software failure is provided (see also [Paragraphs 4.62 - 4.63](#))

Location of controls

- 6.12 Whether within the plant, duct or room, sensors should be located to provide accurate measurement of the condition of the air being monitored.
- 6.13 Sensors and control items such as control valves should be located close to the element being sensed or plant item being controlled, in order to minimise time lags within the system which may create over-shoot of conditions beyond the design envelope and result in additional energy consumption.
- 6.14 There are practical advantages in locating all control valves for an air-handling unit in a bank (at a convenient height) at one end of the unit. (This will not normally result in an undue additional control lag.)
- 6.15 Some applications require intermittent mechanical ventilation, frequently at a high air-change rate, (for example, in bathrooms and treatment rooms.) Local controls to facilitate this mode of operation should be placed in a prominent position to encourage economical use.
- 6.16 Local controls that enable the user to select more than one mode of operation should be clearly labelled to identify the particular mode selected. Where the system allows different room pressures to be selected then a direct-reading

pressure gauge should be fitted within the eye line of the users to provide an independent confirmation of the resultant mode of operation. A clear description of the selectable modes of operation should be mounted adjacent to the control switch.

Fire aspects

- 6.17 A fire control panel should be mounted at the entrance of the area that the ventilation serves. The panel should have restricted access for the fire officer and include independent on/off controls and indication of the supply and extract systems.
- 6.18 In certain critical care departments it is preferable to maintain the supply ventilation in case of a fire within the area. For example, in an operating department, while undergoing surgery, the patient cannot always be easily moved without significant risk. In the event of a fire in a staff or support area of the department, or adjoining zone, the continued supply of air to a theatre will maintain it at a positive pressure and protect the patient and staff from the effects of smoke. This will allow time for the patient to be stabilised so that he/she can be safely evacuated if necessary. A similar situation occurs for patients in ITU and other critical care units. In all of these cases the ventilation to the critical area should continue to operate unless the AHU starts to draw in smoke. For these departments, a notice should be affixed to the fire control panel drawing attention for the need to liaise with departmental staff before switching off fan units.
- 6.19 All supply AHUs should have a smoke sensor mounted in the main supply duct immediately downstream of the AHU. In the event of a fire in the AHU or smoke being drawn into the system from an outside source, it should cause the supply air fire damper to close and shut down the AHU.

Time switching

- 6.20 Facilities to start, set-back and stop the plant should be provided in the plantroom. Remote start and set-back control and indication, if required, should be provided at a manned staff location, for example, at the reception or staff base or, in theatres, within the Surgeon's Panel.
- 6.21 Many ventilation systems may be completely shut down when the area served is not in active use. Alternatively, where there is a need to maintain a background condition, the ventilation output can be reduced by "setting back" the system. This will significantly reduce energy consumption and extend the life of filters and other system components.

Start-up control

6.22 The plant's start control should contain a control logic that will start the plant in the sequence set out in the following algorithms, [Figures 2 - 5](#)

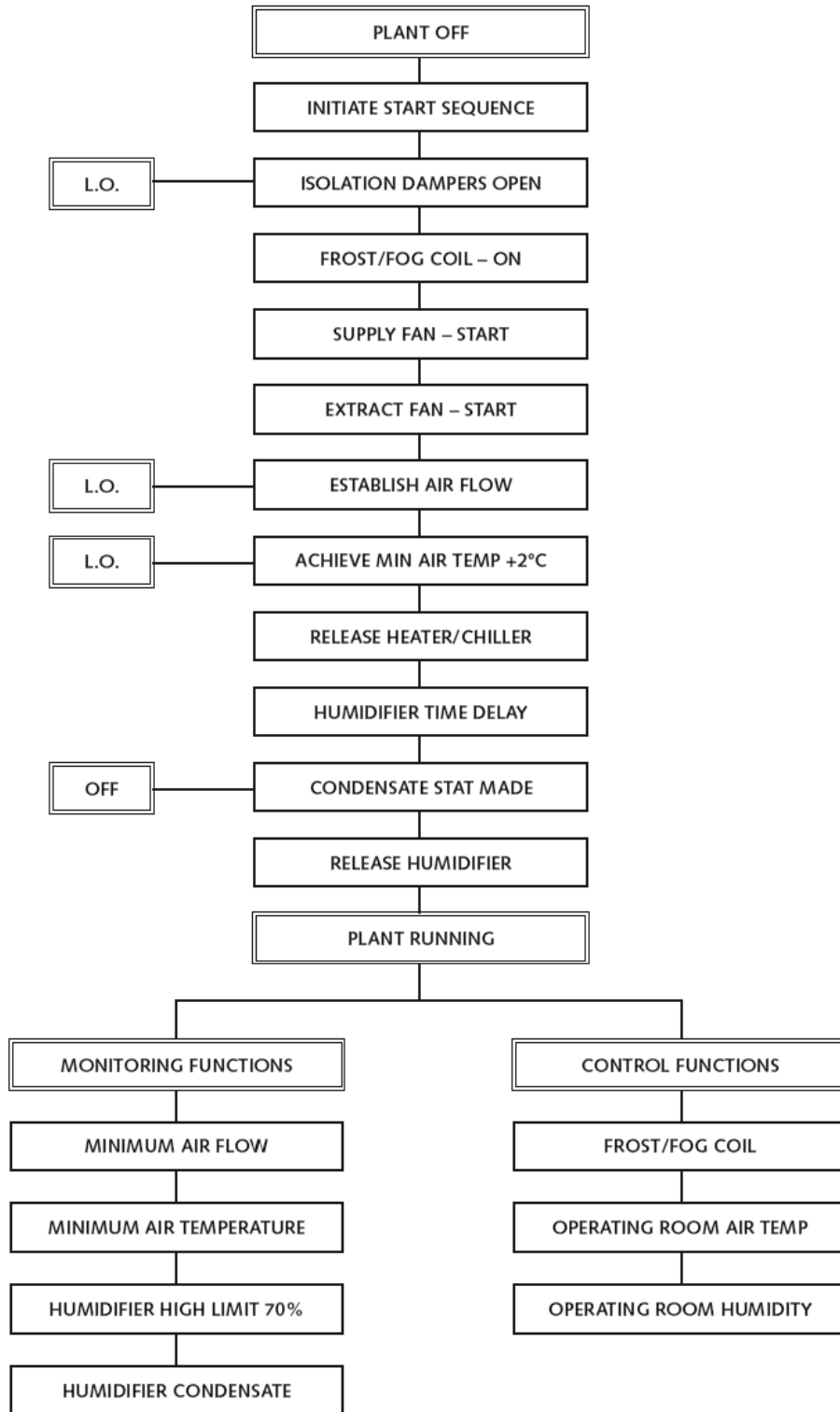

Figure 2: Typical plant control algorithm – normal start-up sequence

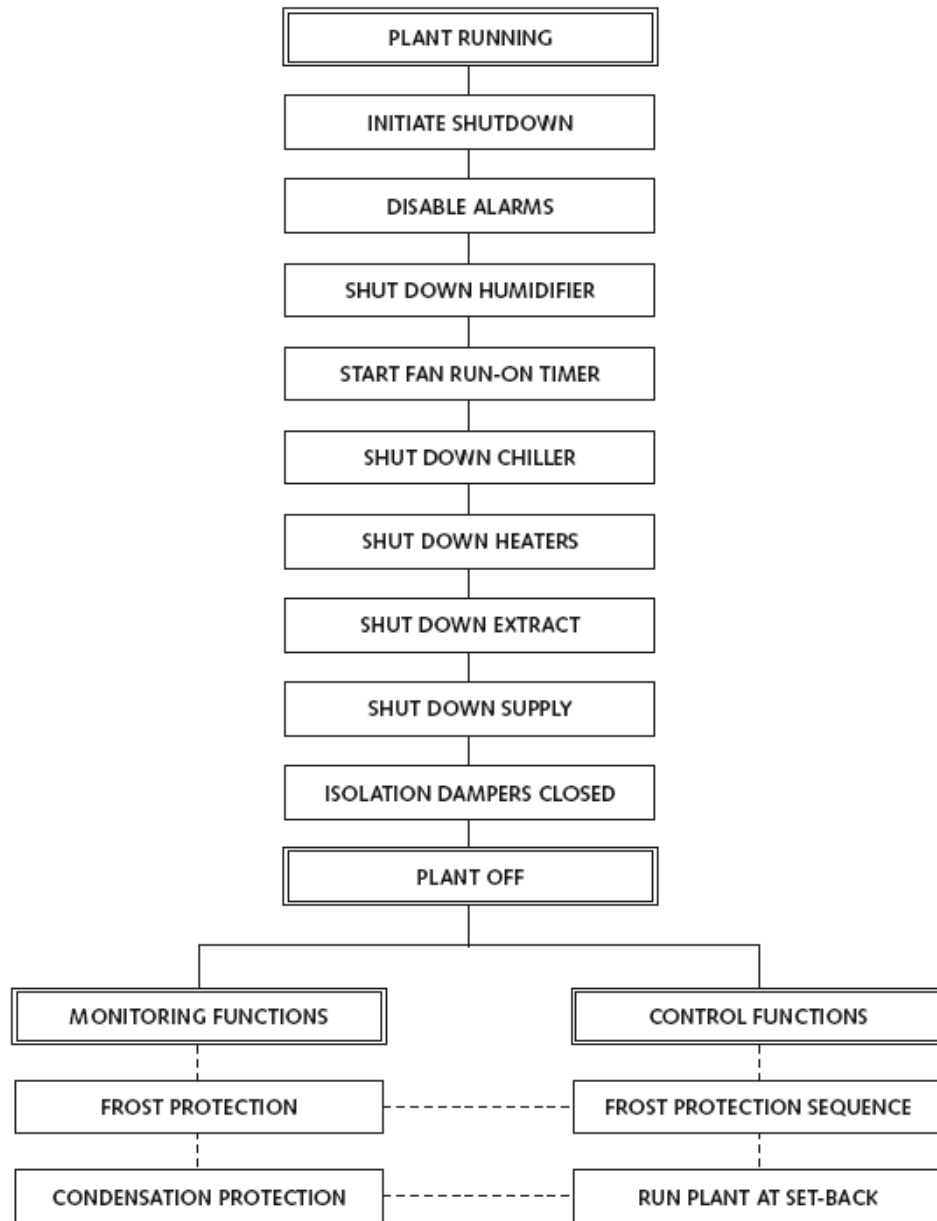

Figure 3: Plant control algorithm – normal shutdown sequence

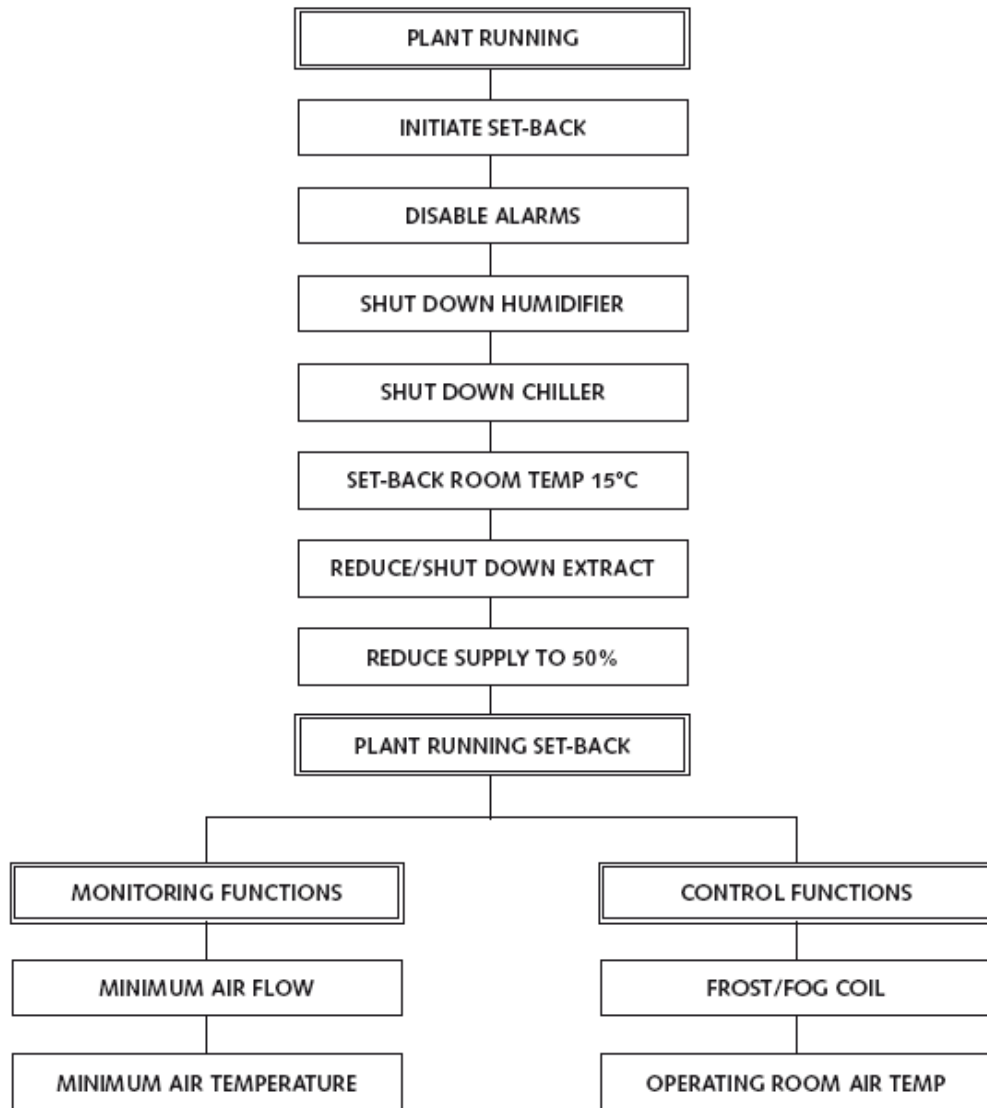

Figure 4: Plant control algorithm – set back sequence

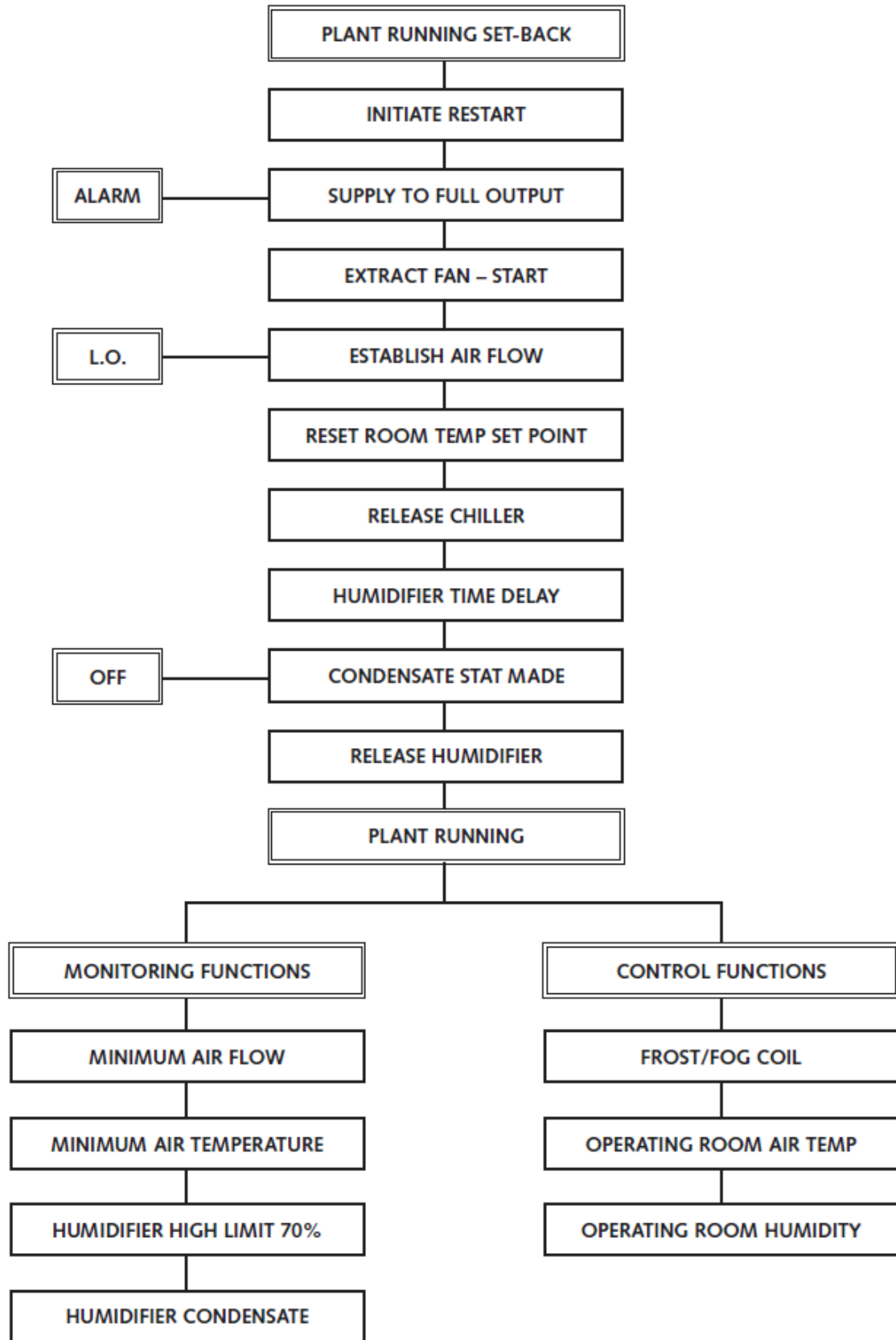

Figure 5: Plant control algorithm – restart from set-back

Set-back control

- 6.23 Where variable speed controls are installed, the setback facility for each plant should depress the control temperature to around 15°C; exclude any humidification and cooling from the system; and reduce the supply and extract air volumes to around 50%. The extract fan can also be turned off as long as the desired direction of air movement from clean to less clean will be maintained (See also [Figures 2 - 5](#)).

Use control

- 6.24 The installation of movement detectors allows for “use control” of ventilation systems. A simple control logic that reduces the system to a “set-back” condition if there has been no movement detected in the space for, say, 30 minutes and that switches the system “off” if no movement is detected for one hour is recommended for many applications, including operating suites.
- 6.25 A variation on this can be provided by linking ventilation controls to lighting. For example, in an operating theatre, the system may be off outside of working hours, could run at set-back when the general lighting was switched on and increase to full speed when the operating lamp is switched on. As with movement detection, a 30-minute run-on should be provided at each stage when the lights are turned off.
- 6.26 Either of the above control strategies may be refined by linking to the BEMS to provide a control logic related to normal working hours and associated ‘real-time’ movement within the zone being controlled. This should result in significant energy savings.

Environmental control

Temperature control methods and application

General

- 6.27 All control valves must fail safe, that is, close in the event of power or air-flow failure, with the exception of the fog/frost battery control valve, which should open upon power or airflow failure.
- 6.28 Control valves should be located in an accessible position. Isolation valves should be provided to enable the control valve to be removed for service without the need to drain-down the system.
- 6.29 Care should be taken to ensure that the installation of control valves and their associated pipework do not obstruct access to the AHU inspection doors and hatches.

Room temperature control

- 6.30 The limits for room temperature set point are generally between 16°C and 25°C depending on the particular application, and in some specialised instances (for example, operating departments) are adjustable within a predetermined range by the user.
- 6.31 The selection of temperature set point for each room or zone may be by a control facility in the room / zone, or remotely at the control panel or BEMS. Where the control device is mounted within the room / zone and adjustable by the user, it should be marked either 'raise' and 'lower' or '+' and '-'. It should control within a specified temperature range to suit the user requirement with a control tolerance of $\pm 1\text{K}$. All other control set-points should be selectable either on the control panel or at the BEMS interface.
- 6.32 Where local control is provided, an indication of temperature will be required locally, or at a staff base (if appropriate), using an analogue or digital indicator. The indicator should be large enough to be read from the normal working position (for example, at the operating table in a theatre). This may be mounted in a supervisory or, 'surgeon's' control panel, with the signal repeated on the main system control panel or BEMS. It is important that this indicator displays the actual measured temperature and not the selected temperature.
- 6.33 Where the supply and extraction systems are designed for ventilation only and there is a wet heating system to provide background heating, care must be taken to avoid one system trying to heat the space while the other system is trying to cool the area.

Frost battery control

- 6.34 Steam-supplied frost batteries must be operated as on/off devices with their sensor mounted upstream of the battery. This will give 'open loop' control. A set point of +1°C is recommended.
- 6.35 Low pressure hot water (LPHW)-supplied frost batteries should be controlled using the proportional mode. Their sensor should be located downstream of the battery to give 'closed loop' control. A set point of between 2°C and 5°C is recommended.
- 6.36 If the temperature downstream of the frost battery, as sensed by a serpentine thermostat, falls below the required set point over any part of the coil, the plant must automatically shut down in order to prevent damage to the other batteries. The serpentine thermostat must not be in direct contact with the coil.

Off-plant control

- 6.37 The control logic must prevent the chiller and pre-heater being on at the same time.

Humidity control methods and application

- 6.38 In order to prevent excessive condensation when starting up from a total plant shut-down, a time delay should be incorporated into the control system such that the humidifier does not start until 30 minutes after the ventilation plant starts up.
- 6.39 Irrespective of the method of control, a high-limit humidistat should be installed to ensure that when the humidifier operates, the condition of the air in the duct does not exceed 70% saturated, particularly during plant start-up.
- 6.40 With certain types of steam humidifiers, it may be necessary to install a thermostat in the condensate line from the humidifier's steam supply, to ensure that the steam at the control valve is as dry as possible before it is injected into the air supply.
- 6.41 The humidifier and cooling-coil control must be interlocked so that they cannot be on at the same time.
- 6.42 The humidifier control system should ensure that it is switched off with the fan. It is preferable to design the control system so that the humidifier is isolated for an adequate time before the fan is turned off so as to purge humid air from the system.
- 6.43 All control valves must fail safe (that is, close in the event of power failure) and the humidifier must be interlocked with the low airflow switch.

Multi-zone control methods and application.

- 6.44 Close control of all air-conditioning parameters may be difficult to achieve with multi-zone systems, since each zone will in theory require a re-heater and humidifier to give total control of humidity if that is what is required. In reality such close control is rarely required in practice. It is therefore usual with multi-zone systems to provide control of zonal temperature only, with humidity control where fitted being based on average conditions within all zones, or minimum conditions within one zone.
- 6.45 Where there is a requirement for close control of air-conditioning parameters in a number of zones (e.g. an operating department) separate plants should be provided for each zone in order to avoid the need for expensive over-cooling and reheating of individual zones.
- 6.46 Most multi-zone systems within healthcare premises are controlled based on off-coil control within the central plant, with trimmer heater batteries on individual zones.

Alarms and indication

- 6.47 Supply and extract systems should include indicator lamps on the control panels to confirm the operational status of each system. Where the usage is on

a regular daily pattern, time control with a user-operated timed manual over-ride should be provided.

- 6.48 Where a system is provided for a particular space, the indicator should be in, or immediately adjacent to, that space and local controls should be provided with labels clearly defining their function (eg. isolation suites.)
- 6.49 The 'plant failure' and 'low air-flow' alarms should be initiated by a paddle switch or other device located in the main air supply duct. This should operate when the air quantity fails to reach or falls to around 80% of the design value and will give indication of fan failure, damper closed, access door left open, or any other eventuality that could cause a reduction of air quantity. Monitoring the current drawn by the fan motor is not a substitute for a sensing device that is directly affected by the air-flow.
- 6.50 The 'filter fault alarm' should be initiated by a predetermined increase of pressure differential across the filters, thereby indicating a dirty filter.
- 6.51 Direct-reading gauges or manometers should be installed across filters to give maintenance staff an indication of their condition.
- 6.52 Visual indication should be provided at a manned staff location (for example, the reception or staff base) and on the main control panel and BEMS to show 'plant failure' and 'low air flow'.

BEMS

- 6.53 Control of most systems will be via a Building Energy Management System (BEMS). This will enable the operating conditions and control tolerances to be set and monitored. The BEMS may also be set to log the actual energy consumed by the system and recovered by the energy recovery system. This will provide a useful check on the overall operating efficiency and provide evidence that energy targets are being achieved.

7. Specialised ventilation systems

7.1 This section contains design information for a range of healthcare ventilation applications.

7.2 The following departments will require a degree of specialised ventilation.

- the Operating department;
 - treatment rooms;
 - endoscopy, day case and minimum invasive suites;
 - cardiology and operative imaging suites;
 - conventional operating theatres;
 - Ultra-clean ventilation (UCV) operating theatres;
 - barn theatres;
 - recovery and ancillary areas.
- Obstetrics;
 - maternity theatres;
 - birthing rooms;
 - LDRP Rooms;
 - SCBU.
- critical areas and high-dependency units of any type;
- Isolation facilities;
 - infectious diseases units;
 - bone marrow and other transplant units;
 - chemotherapy and oncology units.
- Sterile Supply and Decontamination Units;
 - wash rooms;
 - inspection and packing rooms;
 - sterile pack stores.
- the Pharmacy departments;
 - aseptic suites;
 - extemporaneous preparation areas;
 - radio pharmacies.
- the Pathology department;
 - laboratories;

- cat 3 and 4 rooms.
- the Mortuary and Post mortem suite;
 - mortuaries;
 - post-mortem rooms;
 - specimen stores.
- Hydrotherapy units;
- Burns units;
 - burns theatres;
 - treatment rooms;
 - isolation rooms;
 - tissue banks.
- Emerging specialties;
 - gene therapy units;
 - stem-cell laboratories.
- Infrastructure;
 - plant rooms housing combustion equipment;
 - welding facilities;
 - wood working workshops;
 - electric vehicle charging areas.

7.3 Design information for many of these applications is given in [Appendix 1 Table A1](#), [Appendix 2](#) and in the following Chapters within this section.

7.4 It is not possible within this existing document to give definitive guidance for every healthcare specific ventilation application. Additional detailed guidance may be issued in due course in the form of supplements.

General information

7.5 The section on operating theatres is the most extensive and contains much information that is common to other applications. Each theatre suite should have its own dedicated air-handling unit and extract fan. Where no specific guidance is given the principles set out below should be followed:

- the foregoing sections of the document contain general information on healthcare-specific aspects of ventilation system design and specification;
- a set of standard solutions for the design of general operating theatre suites to conform to past and new standards is given in new standard layouts Nos 1, 3, 5 and 7 and those for UCV theatres in new standard layouts Nos 2, 4, 6 and 8 within [Appendix 3](#);

- the CIBSE Guides A & B contain basic information on ventilation design that can be applied to most applications;
- where a British or European standard exists that is specific to the application (for example, a clean room) it should be used as the basis of the design requirement;
- air should always move from clean to less clean areas. A hierarchy of room cleanliness is given in [Table A2](#);
- differential pressure will prevent contamination between areas when doors are closed. Information on air leakage through closed doors and hatches for a range of differential pressures is given in [Table A3](#);
- the flow of air will prevent contamination between areas when doors are open. Information on air leakage through open doors and hatches for a range of differential pressures is given in [Table A4](#);
- if anaesthetic gases are used, 15 air changes per hour will be required;
- a methodology for calculating a design solution for a non-standard suite of operating rooms is given in [Appendix 4](#). This may be adapted as necessary to suit other less complex applications where air is required to cascade from clean to less clean areas.

7.6 The supply of air to a room has four main functions:

- to dilute airborne contamination;
- to control air movement within such that the transfer of airborne contaminants from less clean to cleaner areas is minimized;
- to control the temperature and if necessary the humidity of the space;
- to assist the removal of and dilute waste gases where used.

7.7 Because of the complexities of controlling air-movement patterns, much design effort will be required for this aspect. It is important that the design makes the best possible use of the air available, as excessive supply airflows for the control of air movement should not be used. The amount of air supplied will be determined by the number of doors and desired air-change rate.

7.8 There are four routes whereby airborne contaminants may appear in a room:-

- through the supply air;
- shed directly by the room occupants;
- arising as a result of the work activities;
- transferred from adjacent spaces.

7.9 Particles entering with the supply air can be controlled by the selection of suitable filter grades.

7.10 Particles shed directly by the room occupants can be controlled by:

- restricting access to essential persons only;

- the choice of the occupants' clothing;
- the room's air-change rate.

7.11 Particles arising as a result of the work activity can be controlled by:

- enclosing, semi-enclosing or otherwise controlling the work-based source;
- the room air-change rate.

7.12 The transfer of particles from adjacent spaces can be controlled by:

- differential pressure;
- air-flow paths.

7.13 Air change rates are given in [Table A1](#). These figures have been found to give sufficient dilution of airborne contaminants, provided the mixing of room air is reasonably uniform.

7.14 A downward-displacement turbulent air distribution is generally preferred. The supply and extract diffusers should be positioned to ensure that all parts of the room are actively ventilated and that where necessary the staff will be in a clean air-flow path. (See [Section 5](#) for additional guidance on supply terminals).

7.15 Horizontal-flow room-air distribution with or without a Coanda effect can be a source of draughts and difficult to set up correctly. Its use should be confined to non-critical areas.

Air movement control

7.16 The design of the system should seek to minimise the movement of contaminated air from less clean to cleaner areas. Transfer grilles enable air to pass in either direction between rooms of equal class and pressure. Pressure stabilisers operate in one direction only; they allow excess air to be directed to the area desired and assist in maintaining room pressure differentials. When closed they prevent significant reverse air-flow.

7.17 The relative locations of supply and extract terminals and their design air-volume rates will determine the basic airflow between adjacent spaces. Transfer grilles and pressure stabilisers will permit and control the flow of air between spaces ensuring a flow from the clean to less clean areas. Failure to provide such devices will lead to uncontrolled air flows when personnel move between rooms. They may also result in doors being held partially open by air pressure

Temperature and humidity control

7.18 To achieve the required room conditions, supply flow rates are calculated conventionally, taking account of all heat and moisture gains and losses, and of maximum permissible temperature differences between the room and supply air. In most applications the base heating load will be provided by a heating

system. In critical systems the room or suite being considered will be within the heated building envelope so the ventilation will be sized to suit the casual gains or losses.

- 7.19 Temperature differences of up to 10K for winter heating and 7K for summer cooling must not be exceeded.
- 7.20 It is acceptable for the humidity to swing uncontrolled between 35% and 70% saturation.

Removal and dilution of waste anaesthetic gases

- 7.21 Anaesthetic gases are subject to occupational exposure limits. Waste anaesthetic gas must be contained and removed by a suitable gas-scavenging system. Some leakage from the anaesthetic equipment and the patient's breathing circuit will occur with all systems, particularly during connection and disconnection; and from the interface with the patient. The air movement scheme should ensure that this leakage is diluted and removed from the room. Anaesthetic agents are heavier than air so placing the supply terminal at high level with an extract at low level, adjacent to the anaesthetic gas terminal units will ensure that staff are in a clean air-flow path.
- 7.22 In LDRP and delivery rooms the use of anaesthetic gas is controlled on demand by the patient. This may result in significant leakage which, in order to reduce staff exposure, will need to be controlled by establishing a clean airflow path. A supply at high level at the foot-end of the bed with extract at low level at the head-end will provide such a path.

Fire aspects

- 7.23 When considering the overall airflow movement, careful thought needs to be given to the operation of the ventilation system, to limit smoke spread in the event of a fire.

Door protection

- 7.24 Air should flow from the cleaner to the less clean areas as shown in [Table A2](#). There are several factors that affect the likelihood of a reverse air- flow through doorways:
 - when a person passes through a doorway, both the passage of the person and the movement of the door flap cause a transfer of air between the areas separated by the door;
 - when a door is left open there is a transfer of air between the two areas separated by the doorway. This is caused by air turbulence, but is greatly increased by any temperature differential between the areas (a 1.4m wide doorway may allow the transfer of 0.19 m³/s of air in each direction when there is no temperature difference, but when the temperature differential increases to say 2K, the volume transferred may increase to 0.24 m³/s).

- 7.25 Two methods of door protection are used in order to reduce the likelihood of contamination of clean area by a reverse air-flow from a less clean area:
- closed door protection – a pressure differential is created across a closed door so that any air leakage is from the clean to the less clean area. [Table A3](#) gives details of closed door leakage rates for a range of differential pressures;
 - open door protection – the pressure differential drops (See [Table A5](#)) and is effectively replaced by a flow of air through the doorway from the clean to the less clean area. The flow of air needs to be sufficiently large to ensure that significant reverse airflow cannot occur and will be related to the relative cleanliness of the areas being considered. [Table A4](#) gives air-flow rates for open door protection related to door / opening size and classification of the adjoining areas.
- 7.26 Pressure stabilisers enable the room differential pressure to be set when the doors are shut, thus providing closed-door protection. When a door is opened the stabilisers will close, forcing air to be directed through the doorway thus providing open-door protection.
- 7.27 The recommended air-flow rates to achieve this are given in [Table A3](#). Provided that the dilution criteria in [Table A1](#) are met, the occasional small back-flows created (when two doors are opened simultaneously; or when there is a high temperature difference across an open door) will have little effect on the overall air cleanliness of the affected room.
- 7.28 In applications where it is critical to maintain a specific airflow and /or pressure regime (for example isolation rooms) all windows in the zone should be locked shut or sealed. Trickle vents, if fitted, will also need to be sealed.

Systems design

- 7.29 The design of the ventilation system for an area depends on the overall configuration of the department. Where the department is served by more than one AHU, the control of the units may need to be interlocked so that reverse air-flow patterns do not occur.
- 7.30 Dual-duct high velocity systems have advantages, but are noisy, costly and may give rise to unacceptable values of humidity. Single-duct, low velocity/pressure systems are preferred.
- 7.31 Extract grilles should be sited and balanced to promote air movement in the desired direction.

7.0 (a) Operating department ventilation systems

- 7.32 The information given in this section relates to general operating suites. It will be applicable to other types of theatre suite such as maternity, burns, cardiac, etc. The standard values given may need to be adjusted to reflect non-standard room sizes, pressure regimes and air change rates.

7.33 A method of obtaining a design solution for non-standard theatres is given in [Appendix 4](#).

7.34 Additional information for Ultra-clean ventilation (UCV) theatres is given in [Section 7.0 \(b\)](#).

General

7.35 The supply of air to an operating room has four main functions:

- to dilute airborne contamination;
- to control air movement within the suite such that the transfer of airborne contaminants from less clean to cleaner areas is minimized;
- to control the temperature and if necessary the humidity of the space;
- to assist the removal of, and dilute, waste anaesthetic gases.

7.36 Because of the complexities of controlling air-movement patterns, much design effort will be required for this aspect. It is important that the design makes the best possible use of the air available, as excessive supply airflows for the control of air movement should not be used. The amount of air supplied to the operating room will be determined by the number of doors and desired air-change rate.

7.37 The detailed considerations upon which the supply air-flow rate is based are as follows.

Dilution of airborne bacterial contaminants

7.38 There are four routes that airborne contaminants may appear in an operating room:

- through the supply air;
- shed by operating staff;
- produced by the surgical activities;
- transferred from adjacent spaces.

7.39 Supply flow rates for the main rooms of the operating suite are given in [Appendix 3](#). For the other areas where room sizes and activities vary from site to site, air-change rates are given in [Table A1](#). These figures have been found to give sufficient dilution of airborne bacterial contaminants, provided the mixing of room air is reasonably uniform.

7.40 A downward-displacement air distribution is preferred; it may be either turbulent or laminar flow. For turbulent flow the supply-air diffusers should be positioned either in the centre of each quadrant of the ceiling or along a line between the centres of each quadrant. This should ensure that all parts of the room are actively ventilated and that there will be adequate air movement at the operating table. Laminar flow would be provided by a perforated plenum terminal centred

above the operating table. (See [Section 5](#) for additional guidance on supply terminals).

- 7.41 Suspended articulated equipment is usually fitted in theatres. These require significant structural steelwork in the ceiling void to cater for the loads imposed by the resulting bending moments. It is important to ensure that the void is deep enough to accommodate both the steelwork and the ventilation ducts. The location of the steelwork must not prevent a suitable layout of the ventilation ductwork and correct positioning of the supply air terminals. It needs to be recognised that the correct ventilation of an operating theatre plays a significant part in controlling healthcare acquired infections and is not subordinate to the desire to make equipment easy to move.
- 7.42 Horizontal flow distribution with or without a Coanda effect can be difficult to set up correctly and are unlikely to be as effective in Theatre applications. It should not be used in new installations. However space constraints may force its retention or replacement when refurbishing existing installations. Where fitted, the supply grilles will require a means of directional adjustment.
- 7.43 For general operating theatres, the air supply would be filtered in the AHU. Terminal HEPA filters are not generally required.

Control of air movement within the suite

- 7.44 The design of the system should seek to minimise the movement of contaminated air from less clean to cleaner areas. Transfer grilles enable air to pass in either direction between rooms of equal class and pressure. In older designs suitably dimensioned door undercuts were often used in lieu of transfer grilles. Pressure stabilisers operate in one direction only; they allow excess air to be directed to the area desired and assist in maintaining room-pressure differentials.
- 7.45 The relative locations of supply and extract terminals and their design air-volume rates will determine the basic air-flow between adjacent spaces. Transfer grilles and pressure stabilisers will permit and control the flow of air between spaces ensuring a flow from the clean to less clean areas of the suite. Failure to provide such devices will lead to uncontrolled airflows when personnel move between rooms and doors being held partially open by air pressure.

Temperature and humidity control

- 7.46 Supply flow rates to achieve the required room conditions, are calculated conventionally, taking account of all heat and moisture gains and losses, and of maximum permissible temperature differences between the room and supply air. In most applications the room being considered will be within the heated building envelope.
- 7.47 Temperature differences of up to 10K for winter heating and 7K for summer cooling must not be exceeded.

- 7.48 It is acceptable for the humidity to swing uncontrolled between 35% and 60% saturation.

Removal and dilution of waste anaesthetic gases

- 7.49 Anaesthetic gases are subject to occupational exposure limits. The air-movement scheme should ensure that staff are in a clean air-flow path. (See [Paragraph 7.21](#)).
- 7.50 Air extracted from operating suites should not be re-circulated, as it may contain malodorous contaminants. However an energy recovery system should be fitted in the extract in order to reduce the plant energy consumption. (See [Paragraphs 4.142 - 4.147](#)).

Fire aspects

- 7.51 When considering the overall air-flow movement, careful thought needs to be given to the operation of the ventilation system, to limit smoke spread in the event of a fire. However, this is a highly staffed department with a low fire risk/load status and these factors need to be recognised when developing the fire strategy. It is considered satisfactory to treat the complete operating department as a single fire compartment providing there are at least two exits from it. Over-compartmentalisation can lead to difficulties in establishing clean air-flow paths and room-air dilution rates. This will lead to an increased risk of healthcare-associated infections. Staff areas within the department should be treated as a sub-compartment. (See [Paragraph 6.18](#)).

Door protection

- 7.52 Air should flow from the cleaner to the less clean areas as shown in [Table A2](#). The factors that affect the likelihood of a reverse airflow through doorways are discussed in [Paragraphs 7.24 - 7.26](#).
- 7.53 It is not possible to design an air-movement scheme, within the restraints of the amount of air available that will protect the operating room when two doors are simultaneously opened. The design process that has been used considers that each door is opened in turn and ensures that the direction and rate of air-flow through any open doorway is sufficient to prevent any serious back-flow of air to a cleaner area.
- 7.54 Provided that the air-change rates in [Table A1](#) are met, dilution will be sufficient to ensure that the occasional small back-flows created (when two doors are opened simultaneously; or when there is a high temperature difference across an open door) will have little effect on the overall air cleanliness of the affected room.
- 7.55 The following general points should be taken into consideration during the design of operating suites:

- Number of exits – the fewer the number of rooms (and therefore doorways) leading from the operating room the better, as traffic is reduced and less complicated air-movement control schemes are required.
- Scrub and hand-wash facilities – these may be a part of the operating room, often in a bay. The bay would count as part of the operating room volume and should have a low-level active or passive extract to remove the moisture-laden air. Should a separate room be required for the scrub area, a door between the scrub-up room and the operating room is an inconvenience to scrubbed staff, and could be replaced by an opening. This opening should be larger than a normal single doorway, but the scrub would not, in these circumstances, be considered part of the operating room volume.
- If an alcohol scrub regime is employed, individual theatre scrubs may not be required and would be replaced by a common departmental pre-/post-operation scrub position in the corridor. This would require local extract to prevent a build-up of moisture.
- Preparation ‘Sterile Pack Store’ (SPS) – if it is intended to ‘lay-up’ instruments in the operating room, the preparation room is then used simply as a sterile pack store. The nominal room pressure can therefore be the same as that of the operating room and the airflow between the two rooms in either direction. Air supplied to the preparation room may be directed into the operating room either through a door mounted transfer grille or if no door is fitted, through the opening. Alternatively, stock ready-use sterile items can be located in a bay within the theatre. In this case, a portion of the total theatre supply air should be provided in the bay to ensure it is actively ventilated.
- Preparation room ‘lay-up’ – when the preparation room is used as an instrument ‘lay-up’ room, it should be regarded as being of greater cleanliness than the operating room, and the design should minimise the transfer of air from the operating room to the preparation room. Air supplied to the room may be directed to the operating room through a pressure stabiliser taking care not to compromise the airflow pattern in the operating room. The air may also be directed into a corridor;
- Service corridor – if materials to be disposed of are placed in impervious material for transportation, it is not necessary to have a separate corridor for this purpose. However, a service corridor has many operational advantages in terms of the flow of materials through the theatre suite. It also permits routine service and maintenance access without compromising the use of adjacent theatre suites.

Standard air-movement control schemes

7.56

In the previous versions of this guidance standard air movement control schemes were given that provided a range of design solutions to typical operating suite layouts. These were satisfactory design solutions for ‘standard’ sized rooms within the suite but were never intended to be universal for any sized room or suite. Guidance on operating suites contained in HBN 26 (2004) has increased the recommended size of operating room from approximately

35m² to 55m². Associated room sizes and air change rates have also increased. This means that the original standard solutions are no longer appropriate for new-build installations.

- 7.57 Because of the resulting increase in the volume of air supplied to the theatre, provision needs to be made either to actively remove it or allow it to escape passively through pressure stabilisers. The increase in room size has also made the number and position of air-supply terminals critical to the effective ventilation of the room.
- 7.58 Four new standard solutions have been developed to reflect the current guidance on theatre suite layout and room sizes given in HBN 26 (2004) as well as the general increase in air-change rates.
- 7.59 The most commonly used original standard solutions have been revised and updated. They have been retained in this guidance, as they will remain applicable to older theatre suites that are being refurbished to their original performance standards. They will also be applicable in existing departments where space constrains do not permit the upgrading of suites to the latest standard of performance or where a pre-built “shell” is being fitted out.
- 7.60 It is important to recognise that in any situation where a “non-standard” room size or theatre suite layout is being considered, the designer must return to first principles when developing a solution. Examples of non-standard configurations would be:
- cardiac theatres that typically have an operating room half as big again as normal, a perfusion laboratory and no anaesthetic room;
 - operating departments served by a central instrument lay-up preparation area rather than individual prep rooms;
 - balanced-flow theatres for infectious cases.

[Appendix 4](#) contains a methodology for assisting the designer to arrive at a suitable solution.

- 7.61 The new and revised standard design solutions are as follows:
- No 1 – Typical Conventional theatre – room sizes as HBN 26;
- No 2 – Typical UCV theatre – room sizes as HBN 26;
- No 3 – HBN 26 illustrated Conventional theatre;
- No 4 – HBN 26 illustrated theatre with UCV terminal fitted;
- No 5 – Pre-2006 Conventional theatre, single corridor (SHTM 2025; 1b);
- No 6 – Pre-2006 UCV theatre, single corridor (SHTM 2025; 1a);
- No 7 – Pre-2006 Conventional theatre, two corridor (SHTM 2025; 5b);

No 8 – Pre-2006 UCV theatre, two corridor (SHTM 2025; 5a).

- 7.62 Details of these standard solutions are given in [Appendix 3](#). They contain diagrams that show the relationship of rooms and the various doors and transfer devices between them, **but should not be regarded as architectural layouts**. The schemes have been developed using the calculation procedure described in [Appendix 4](#). Important features of the solutions are:
- Zone trimmer heaters – a trimmer heater battery is advocated when calculations indicate that the temperature differential between rooms may be greater than 2K. Generally this will only be the case in the preparation room when designated as a lay-up.
 - The preparation room (sterile pack store)/operating room interface – these rooms are deemed to be of equal cleanliness, and thus a transfer grille is required between these rooms or the door can be replaced with an opening wider than a standard door.
 - Preparation (lay-up)/disposal room interface – pressure relief dampers are recommended here to provide an air path when doors are closed, while preventing back-flow when a door is opened elsewhere.
 - Operating room/anaesthetic room interface – pressure stabilisers, or in some cases, carefully sized transfer grilles are recommended here, and between the anaesthetic room and corridor, and between the operating room and corridor.
 - Operating room/scrub room interface – an opening is provided between these rooms. The flow of air through the opening provides protection, and gives bacterial dilution within the scrub room; the air is then exhausted to the corridor via a pressure stabiliser.
- 7.63 No mechanical supply or extract ventilation is provided in the scrub room, and thus when a door is opened elsewhere in the suite, the stabiliser will close, allowing the air to be re-directed to help protect the doorway. If the scrub is a bay within the theatre then a suitably positioned pressure stabiliser and / or active extract should be provided to ensure air movement and prevent a local build-up of moisture.
- 7.64 Any other scheme may be used and the standard solutions applied, if the following conditions are met:
- room relationships in air network terms are as shown in the plans;
 - door-gap measurements approximate to those given in Scottish Health Technical Memorandum 58: 'Internal doorsets', (but see also [Table A3](#) and [Note 3](#));
 - casual heat gains are accounted for;
 - a trimmer battery is installed in the air supply system to the preparation room;
 - leakage through the structure is kept to a minimum.

Note 3: It should be noted that many doors are now fitted with cold smoke seals as standard. These will significantly reduce the door leakage rate when new and undamaged. It is therefore recommended that provision for the design door leakage is factored into the sizing of the appropriate transfer grille or pressure stabiliser. Failure to do this will result in air gap whistles and doors being held partially open by air pressure.

- 7.65 It is recommended that every effort should be made to adopt one of the schemes described above.

Air terminals and air distribution within rooms

- 7.66 The selection and sighting of air diffusers will be critical in establishing an efficient pattern of mixing. To this end the diffusers selected must be fit for purpose. Ceiling mounted circular ‘air master’ style, square ‘four-way blow’ or similar diffuser designs that provide a downward displacement, turbulent airflow are the preferred option. (See [Paragraph 5.68](#)).
- 7.67 Plenum-type ‘laminar’-flow-style diffusers with a footprint that encompasses the operating site are acceptable but may be prone to buoyancy effects as a result of temperature difference. Manufacturers’ type-test data should be consulted to ensure that the terminal will achieve the required performance envelope. Note that these are not true laminar-flow systems in the strict sense of the word but produce a downward-displacement parallel-flow style of air distribution.
- 7.68 The diffuser equipment chosen should not cause ‘dumping’ and it should provide a velocity 1 metre above floor level at the operating position of between 0.2 m/s and 0.3 m/s.
- 7.69 In the operating room, the supply air terminals must be at high level, and should all be adjustable for rate of flow as well as being easily cleaned and silent in operation.
- 7.70 In order to ensure that all parts of the operating room are actively ventilated, there should be an air-out path on each face or in each corner of the theatre. This may be provided by a pressure stabiliser, transfer grille, active or passive extract terminal. A minimum of three, but preferably four, air-out paths - approximately equally spaced - should be provided.

Automatic control

- 7.71 The automatic control of ventilation in operating suites needs to be simple and robust. Over-reliance on complex room pressure and flow relationships linked to automatic fan speed control is unnecessary and in the long term have been shown to be unreliable. Complex software algorithms that can only be accessed and interpreted by off-site specialists should not be used. Whichever control strategy is chosen it is important that on-site staff have the facility to override the control system and keep the ventilation operating at least until the surgical procedure is complete. (See also [Paragraph 6.11](#))

- 7.72 Theatre air-conditioning control sensors should be actively ventilated. They would typically be located in a sampling extract duct mounted in the surgeon's panel, positioned at normal working height (1.8m above finished floor level) and be accessible for cleaning and the removal of fluff and lint.
- 7.73 Wall-mounted passive-temperature and humidity sensors are not recommended.
- 7.74 Controls should be provided to enable operating department ventilation plants to be closed down when the operating suites are unoccupied. (See also [Paragraphs 6.24 - 6.26](#))
- 7.75 When in the 'off' mode, the control system should ensure that the ventilation plant is automatically reinstated if the space temperature falls below 15°C.
- 7.76 The theatre control panel should include plant status indication; clearly-readable temperature and humidity indicating gauges; and means of adjusting the set point for temperature. Theatre ventilation plant status indication should be located at the staff control base.
- 7.77 Where it is considered necessary to fit a humidifier, it should be selected to humidify to 40% saturation at 20°C during the design winter outside conditions. The cooling coil should be able to remove sufficient moisture so that 60% saturation at 20°C is not exceeded during the design summer outside conditions.
- 7.78 Each operating suite should be served by an independent supply and extract plant.

Ventilation of operating department ancillary areas

General

- 7.79 There are advantages in providing mechanical ventilation to all areas of the department. Maintaining operating suite airflow patterns is simpler and grilles and diffusers can be sited to eliminate condensation on windows. Where radiators or embedded wall or ceiling panels are installed they should be confined to the corridors and staff-only areas of the department.

Ventilation requirements

- 7.80 [Table A2](#) gives guidance on the operating department areas in descending order of cleanliness, and this should be considered in the overall design of the department ventilation systems. The specified flow rates of air through doors given in [Table A4](#) for the operating suite are not necessary for other areas of the department. However, the air-flow directions must be maintained from the clean to the less clean areas.
- 7.81 All windows in the department should be double-glazed and hermetically-sealed in order to ensure that the desired airflow pattern is maintained under all

external environmental conditions and to avoid infestation. Trickle vents if fitted will need to be sealed.

Systems design

- 7.82 The design of the ventilation system for the ancillary rooms depends on the overall configuration of the department. The plant for the ancillary rooms may need to be interlocked to the theatre suite plants so that reverse air-flow patterns do not occur.
- 7.83 Extract grilles should be sited and balanced to promote air movement along the clean and access corridors towards the reception/transfer areas. This should not affect the air distribution in the operating suite(s).

Reception

- 7.84 The aim in these areas is to provide comfortable conditions having regard to the movement control requirements of the department as a whole. The number of air changes will depend on the particular design.

Sterile pack bulk store

- 7.85 The store needs to be maintained at a positive pressure in order to preserve the cleanliness of the outside of the packs; 6 air changes are recommended.

Recovery

- 7.86 The air-change rate in the recovery room will be rather higher than that needed merely to provide clean, comfortable conditions, as it is necessary to control the level of anaesthetic gas pollution; 15 air changes are recommended, with a balanced air flow.
- 7.87 The supply air terminals should be ceiling mounted above the foot-end of the recovery bed positions. Extract should be at low (bed height or below) level behind the bed head positions or in the corners. This will establish a clean airflow path so that staff do not inhale anaesthetic gases exhaled by recovering patients.

7.0 (b) Ultra-clean ventilation systems

General requirements

- 7.88 The design philosophy of a conventionally ventilated operating suite is based on the need to dilute contaminants and control both the condition and movement of air in an operating suite. Ultra-clean ventilation (UCV) is a means of significantly increasing the dilution effect by providing a large volume of clean filtered air to the zone in which an operation is performed and sterile items are exposed. Air is discharged above the operating zone and while not truly laminar, its downward displacement purges the clean zone of contaminants and

particles generated by the activities within it. The airflow in and around the clean zone also serves to prevent particles originating outside the zone from entering it. The resulting reduction in contaminants has been shown to reduce significantly post-operative sepsis following certain orthopaedic procedures.

- 7.89 The number of bacteria that are present in the air at the wound site and exposed surgical items is dependent on the operating team, their procedural discipline, choice of clothing and the type of UCV system. Ultra-Clean air is defined as that containing not more than 10 CFU/m³.
- 7.90 UCV systems are very successful in reducing contaminants at the wound site so it is often considered that there is no need for complex air movement control schemes in the rest of the suite. However, when designing the ventilation scheme, it should be noted that the users may switch the UCV terminal to “set-back” when non-orthopaedic surgery is taking place. This is because the high airflow rates can cause increased moisture evaporation of exposed tissue that may be detrimental to the surgical outcome. In recognition of this, the ventilation scheme should be capable of providing operating conditions to at least a “conventional” theatre standard throughout the suite with the UCV in set-back mode. It should also be remembered that suitable levels of ventilation will always be required in the peripheral rooms.
- 7.91 UCV systems can be designed and built from first principles or a range of bespoke modular units of varying shapes and sizes are available with each manufacturer having a slightly different approach to UCV design. Some systems are fitted with partial or full walls to delineate the clean zone and direct a laminar or exponential downflow of air within it. Other designs utilise slotted linear supply terminals to produce an air curtain around the clean zone together with laminar-flow diffusers to provide a downward-displacement supply within it. **Notwithstanding any variation in the design philosophy, all UCV systems will be required to achieve completely the performance standard set out in the “Validation” section of this document. (Section 8)**
- 7.92 As with conventional theatres, each UCV operating suite should have its own dedicated air handling unit (AHU) to the standard set out in [Section 4](#) of this document. To ensure operational flexibility and permit routine maintenance, air handling units should not be shared between suites.
- 7.93 In retrofit installations, site conditions may preclude individual AHUs for each suite. In these circumstances an AHU may be shared between not more than two operating suites providing each suite has its own control of temperature. An accessible airflow measurement test point should be provided in the supply branch duct to each theatre so that the primary air volume to each UCV canopy can be determined. In addition the branch supply and extract should be capable of being physically isolated and the main air-flow rate reduced so that either suite can be taken out of use without detriment to operating conditions in the other.
- 7.94 An inherent feature of a UCV system is its large airflow so it is essential to re-circulate the air supplied to the operating theatre and/or to recover its energy in order to optimise operating costs.

- 7.95 The primary fresh-air volume supplied to a UCV suite will be the same as in a conventional suite and it should be dispersed to the rooms in the suite in the same manner. This is an important aspect of the design and requests by UCV suppliers for increased primary air-supply volumes should be resisted.
- 7.96 Laying-up in the clean zone is preferable for infection control reasons. Where a Sterile Pack Store (SPS) Preparation room is provided a transfer grille will be required in the preparation room / theatre door.
- 7.97 If the Preparation room is intended to be used for laying-up instruments, a pressure stabiliser will be required between the prep room and theatre. It should be fitted with a stand-off baffle to prevent air transfer interfering with the ultra-clean airflow distribution.
- 7.98 Separate scrub-up or disposal facilities are not necessary for air cleanliness although operational policy may prefer such a provision. A separate anaesthetic room should, however, be provided.
- 7.99 There is no aerobiological reason why two or more UCV systems should not be installed in a common area as long as adequate spacing is provided. These are known as “barn theatres” and require special design considerations and operational discipline. The relative positions of the UCV units, temperature control range and location of doors and openings to other areas will all significantly affect the airflow at the operating positions.

Types of UCV system

Remote plant systems

- 7.100 In a remote plant system, all the air-conditioning equipment is located outside of the operating room, except for the unidirectional air-flow terminal, terminal filter, air diffuser and the return-air grilles (see [Figure 6](#)).

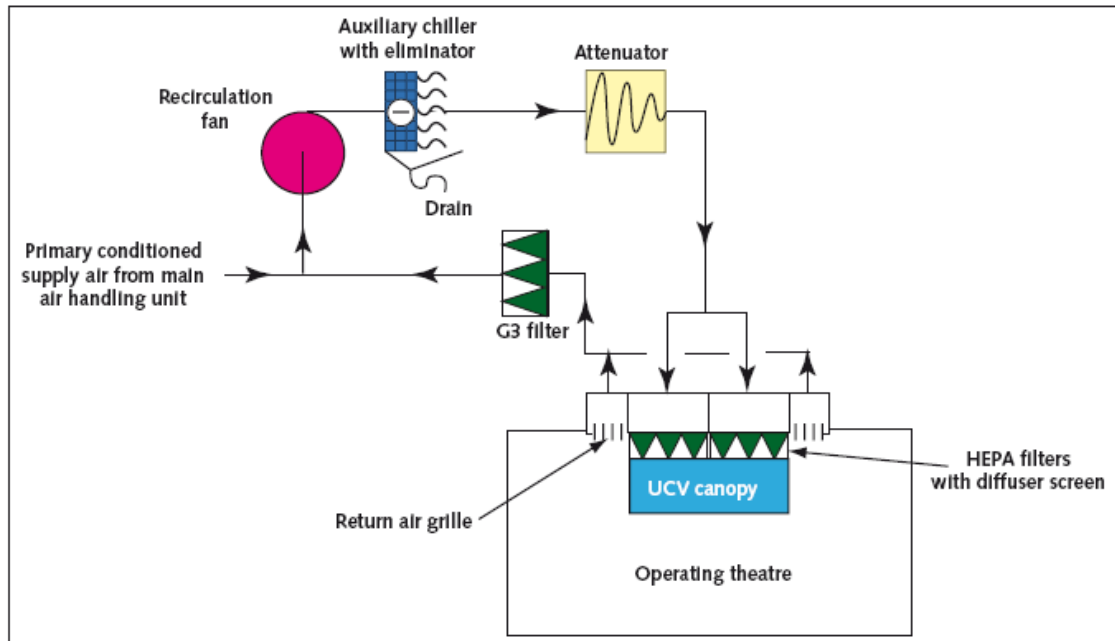

Figure 6: UCV theatre with remote air recirculation

7.101 This arrangement is the preferred option for new installations as it has the following advantages:

- the recirculation fans are out of the theatre thus reducing noise. Multiple recirculation fans can be replaced by a single fan unit with its drive out of the air stream;
- casual heat gains from recirculation fan(s), canopy lights, equipment and people within the theatre can be removed by a chiller battery in the return air stream. This will prevent heat build-up in the theatre;
- the return-air filters can be changed without needing access to the theatre making routine maintenance more feasible;
- the opportunity exists to locate the HEPA filter in the primary supply duct rather than the theatre terminal. This will reduce the number of filters required and allow them to be changed without entering the theatre.

Modular systems

7.102 Modular systems are frequently used in retrofit applications. Vertical or horizontal units are available.

7.103 Vertical-flow modular units comprise a ceiling-mounted air-terminal module containing return-air filters, return-air fans, final filter and air diffuser. Primary air is supplied by a remote air-conditioning unit at the volume and to the standard required for a conventional operating suite. (see [Figure 7](#))

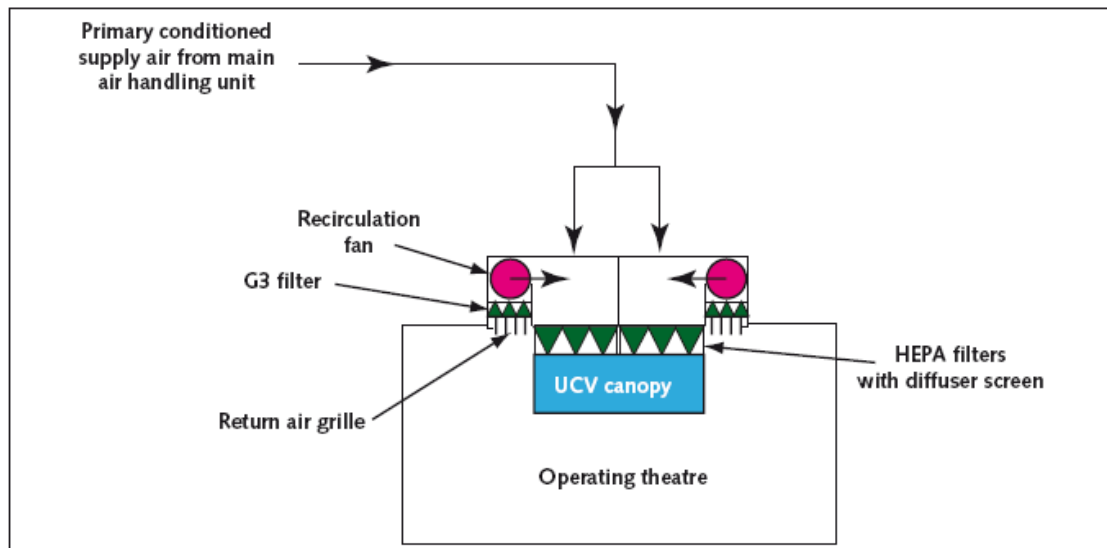

Figure 7: UCV theatre with modular system

- 7.104 Horizontal or cross-flow modular units comprise a wall-mounted air-terminal module standing vertically to produce a horizontal flow of air and containing final filter/diffuser, return-air filters and fans. The module may incorporate a cooling unit or be supplied with ‘fresh air’ from a separate primary cooling system.

Vertical flow UCV systems

- 7.105 Vertical-flow systems have a superior performance and are more effective at reducing infection risks. Air-curtain or partial-wall systems are acceptable, but are known to be more susceptible to problems arising from performance deterioration, poor operating-team discipline and high occupancy rates than is the case with full-wall systems. A full-wall is considered to be any wall terminating not more than one metre above the finished floor level.
- 7.106 Because of the large volume of air being moved in a relatively small space, the siting of the return-air grilles can cause short-circuiting of the air discharged through the UCV terminal. If the return-air grilles are positioned at high level, partial walls should be provided to control short-circuiting. The partial-walls shall be not less than 1m from the operating room walls and terminate at least 2m above floor level. The clearance should be increased proportionally for larger terminals (that is, 1.15m for 3.2m x 3.2m units and 1.25m for 3.5m x 3.5m units). In all cases, the sidewalls should terminate at 2m above floor level.
- 7.107 Siting the return-air grilles around the periphery of the theatre at low level will eliminate short-circuiting, remove the need for partial walls and give an improved airflow path. In any event there should be an air-out path on each face or in each corner of the theatre. These may be provided by combination of pressure stabilisers and passive or active low level extract grilles. Failure to provide air-out paths on all faces of the theatre may result in the surplus air causing entrainment into the clean zone.
- 7.108 Vertical systems should have a clean zone large enough to encompass the operating site and all of the instrument trays likely to be needed for the surgical procedures to be undertaken. Ophthalmic and minor hand surgery would

typically require a 1.4m circular or rectangular terminal. For major orthopaedic procedures a minimum size of 2.8m x 2.8m will be required. This is the area projected on the floor under the supply air terminal within the partial walls, full walls or air curtain. Any air outside this zone cannot be guaranteed to be ultra-clean although given the dilution factor the level of microbiological contamination will be much lower than the general level in a conventional operating room. The use of lines or a coloured area on the floor delineating the extent of the clean zone will assist staff and is therefore essential.

- 7.109 When upgrading an existing conventional theatre to an ultra-clean standard the only solution may be the installation of a modular system. In these units, the heat gains from the return-air fans and terminal lights may warrant the inclusion of supplementary cooling within the module although modern luminaries contribute substantially less unwanted heat. However issues of cooling coil drainage, condensate removal and maintenance access within the space constraints of the module may make this option impracticable. The additional cooling load should then be catered for by conditioning the primary air to compensate.
- 7.110 If an existing AHU is to be retained, it may require modification to ensure that it achieves the minimum standards set out in [Section 4](#) of this document. The fan may need re-rating to accommodate the change in system resistance. The cooling coil may also need to be upgraded to cater for the increased load resulting from the return air fans and terminal lights. Failure to make adequate provision for this may make the theatre unusable during prolonged warm spells.
- 7.111 A factor affecting the air-flow pattern is the supply or room air temperature difference. When the supply-air temperature is significantly above room temperature, buoyancy effects will reduce the volume of air reaching the operating zone. If it is anticipated at design stage that this will be a regular occurrence, then a system incorporating full-walls should be used. Demountable extensions that convert a partial-wall to a full-wall unit are available.
- 7.112 Convection up-currents from the surgical team and operating lamp tend to counter the movement of clean air towards the operating site, hence the air velocity reaching the operating level is critical. The minimum velocity given below has been selected to take account of these factors and is greater than the theoretical minimum value.
- 7.113 For all vertical UCV systems the design discharge velocities will be as follows:
- Air velocity 2 metres above floor level:
- partial-wall system = 0.38 m/s average;
 - full-wall system = 0.30 m/s average.
- Air velocity 1 metre above floor level:
- all systems = 0.2 m/s minimum within the operating zone.

The validation [Paragraphs 8.75 – 8.86](#), gives details of the method of measurement.

- 7.114 Variable-speed recirculation fans with differential pressure control may be the most suitable solution for maintaining consistent performance and energy saving.

Horizontal UCV systems

- 7.115 Horizontal UCV air-flow systems have been shown to be less effective than vertical systems and are not the preferred solution. There may be occasions, however, where architectural, engineering, economic or workload considerations prevent the installation of a vertical-flow system and only a horizontal-flow system can be installed.
- 7.116 Horizontal- or cross-flow modular units comprise a wall-mounted air terminal standing vertically to produce a horizontal flow of air across the operating field. The terminal module contains the final filters, air diffuser, return-air grilles, filters and fans. The module may incorporate a full air-conditioning unit or be supplied with ‘fresh-air’ from a separate primary air-conditioning system. In the latter case the return-air fan power may warrant the inclusion of a supplementary cooling coil within the module.
- 7.117 The system should have sidewall panels at least 2.4m apart. The panels may fold to facilitate cleaning of the theatre. The minimum height of the terminal should be 2.1m and a deflector at the top of the filter/diffuser will be acceptable as an alternative to a full roof. These dimensions reflect currently available equipment and may impose operational constraints in addition to a lower level of performance common to these systems.
- 7.118 In the horizontal flow systems, personnel working between the filter and surgical wound will disperse bacteria that are more likely to contaminate exposed surgical instruments and enter the wound. This may be minimised by the use of improved clothing and operating procedure to reduce dispersion of bacteria. The use of lines on the floor delineating the extent of the clean zone and hatching or colour coding the ‘no-entry’ zone between the air diffuser and patient will serve to prompt staff and are therefore essential.
- 7.119 The air discharge velocity as measured 1m from the diffuser face should have a mean value of 0.4 m/s. The validation [Section 8](#) gives details of the method of measurement.

Filters

- 7.120 The main plant primary and secondary filters should be to the standards and in the location set out in [Section 4](#).
- 7.121 Terminal filters should be provided within the airflow terminal or in the air supply to it. High efficiency particulate air (HEPA) filters grade H10 as specified in BS EN 1822 will be required as a minimum. There is no aerobiological benefit in

fitting filters of a higher grade than this, although for practical reasons most UCV manufacturer recommend the fitting of H12-grade filters.

- 7.122 In some modular UCV units, the terminal filter is used as a pressure equaliser to balance airflow and filters of a higher grade with a greater pressure drop may be recommended by their manufacturer. The increased resistance may affect the velocity of air reaching the operating level and there will be penalties in terms of installed fan power and higher noise levels.
- 7.123 The final filters should be installed in a leak-proof housing in a manner that allows the terminal unit, filters and their seals to be validated. A challenge test will be carried out during commissioning to prove the effectiveness of the complete installation.
- 7.124 Where UCV units are constructed in sections, a means of measuring the pressure drop across the terminal filters in each section should be provided. The pressure test-points should be located outside of the partial wall, capped to prevent air leakage and accessible within the theatre without the need to open the unit inspection panels. Alternatively direct-reading pressure gauges should be fitted.
- 7.125 The UCV system will require a return-air filter to capture the relatively coarse particles that would otherwise significantly reduce the life of the final filter. This should be at least a G3 grade to BS EN 779. In remote recirculation systems there may be advantages in fitting a higher grade return air filter, as it will reduce the load on the terminal HEPA filters and extend their life.

Noise level

- 7.126 If sound-attenuating material is used to line any portion of the inside of the UCV unit it should be non-particle-shedding and fire-resistant. (Further guidance can be found in SHTM Firecode suite of documents).
- 7.127 The maximum noise level in an operating room fitted with a UCV terminal of any type shall not exceed 50 NR. The validation section gives details of the method of measurement.

Lighting and operating lights

- 7.128 CIBSE lighting guide LG2 and BS EN 12464-1 give detailed information of lighting requirements. Operating luminaires should comply with the photometric requirements detailed in relevant sections of BS EN 60601.
- 7.129 The position of the UCV light fittings and style of partial walls, where fitted, should neither adversely disturb the airflow nor result in significant spatial variations in illuminance levels.
- 7.130 In vertical units, specialised task lighting should be provided by toroidal, cruciform or small multiple dome-shaped luminaires as they have good aerodynamic properties. The ideal luminaire will have a minimal effect on the airflow regardless of where it is positioned. Large-diameter saucer-shaped

luminaires should not be used in vertical-flow systems as they will occlude the airflow in the critical central zone. It is important to consider the suitability of existing luminaires when retrofitting UCV systems.

- 7.131 In vertical UCV installations a minimum of 2.75m from floor to underside of the diffuser is required to allow for supporting mechanisms and lamp articulation. When upgrading existing systems this dimension may not be achievable. However, when parked, the lowest point of the central light stem, luminaire and articulation arms should never be less than 2m above floor level.
- 7.132 The traditional means of light support is a central column that passes through the UCV terminal and is rigidly fixed to the building structure. The position of the support therefore prevents air being supplied at the centre of the terminal. Separate supports displaced from the centre of the clean zone would lead to improved airflow. This approach was advocated in the 1994 version of HTM 2025 but at the time of writing no UK manufacturer has chosen to adopt this solution.
- 7.133 In horizontal units the size or shape of the specialised task luminaire has little effect on the air-flow pattern.

Controls and instrumentation

- 7.134 The functions of the supply AHU and extract ventilation should be continuously monitored by a BEMS control unit. The controls and instrumentation for the main plant are set out in [Section 6](#).
- 7.135 UCV systems will additionally require:
- a set-back facility that can reduce the air supplied through the UCV terminal to a volume that equates to not less than 25 air changes per hour of the operating room gross volume whilst still leaving the supply AHU operating at full speed;
 - a facility to turn the entire system, supply AHU and UCV terminal, off. (an emergency stop is not required);
 - a read-out sufficiently large to be clearly visible from the operating table that shows the temperature of the air being supplied by the UCV terminal;
 - a read-out sufficiently large to be clearly visible from the operating table that shows the relative humidity of the air being supplied by the UCV terminal;
 - a red indicator light that will illuminate when either the supply AHU or the UCV terminal fails, either or both are switched off or are at set-back;
 - an amber indicator light that will illuminate when the UCV terminal is at set-back and the supply AHU is running;
 - a green indicator light that will illuminate when both the supply AHU and UCV terminal are operating at full speed;
 - a blue indicator light that will illuminate when the UCV terminal air flow, as detected by a differential pressure sensor, falls below 80% of the design flow rate.

AHU	UVC terminal	Indicator light	Comment
Off or Fault	Off or Fault	Red	Ventilation not operating at a suitable level to commence surgical procedures
Off or Fault	On (set-back)		
Off or Fault	On (full speed)		
On (set-back)	Off or Fault		
On (full speed)	Off or Fault		
On (set-back)	On (set-back)		
On (full speed)	On (set-back)	Amber	Ventilation provided to at least conventional theatre standard
On (full speed)	On (full speed)	Green	Full UCV standard conditions
-	-	Blue	HEPA-filter resistance causing low air flow

Table 7: Indicator light logic table

- 7.136 The switching devices and indicators should be incorporated in the surgeon’s panel and their functions clearly labelled. In retrofit installations an auxiliary panel for the UCV may be the most practical option. If fitted it should be mounted adjacent to the surgeon’s panel and their control functions interlocked as necessary.
- 7.137 When a system is designed to have partial walls with full-wall extensions, a volume control facility may be incorporated to allow the system to be run with reduced velocity when the demountable full-walls are in place. It would be the responsibility of the user to ensure correct operation of the system. To assist the user an explanatory notice should be included on the theatre control panel.
- 7.138 A direct-reading gauge should be fitted in the theatre to show a representative pressure drop across the final filters. If the UCV control box is located out of the theatre and has a means of manually adjusting the return air-fan speed then it should also be fitted with a direct-reading differential pressure gauge. The means of adjusting the return-air fan speed should be lockable to prevent casual adjustment. The direct-reading gauges should be fitted with a means of indicating the correct operating pressure range.
- 7.139 The UCV-unit manufacturer’s control box should be located in an accessible position preferably in the operating department adjacent to the operating theatre that it serves. A service corridor, if provided, is an ideal location. The control box should be clearly labelled with the identity of the operating theatre that it serves.

7.0 (c) Extract systems

- 7.140 Extracts may be provided for a variety of reasons including:
- simple odour control (for example in a WC or mortuary);
 - to receive and remove moisture-laden air (for example, in a kitchen);
 - as part of a combined supply/extract balanced system (for example, in an operating suite);

- to capture a hazardous substance at source (for example a safety cabinet).
- 7.141 Devices that use an inflow of air to control exposure of staff to hazardous substances are classified as Local Exhaust Ventilation (LEV) systems under the COSHH Regulations.
- 7.142 An LEV system may comprise a self-contained unit incorporating its own carbon filter such as a simple bench-top fume cupboard. Alternatively it may be a complete “ventilation system” comprising a make-up air supply, multiple-exhaust-protected work stations, branch and central extract ductwork, duplex extract fans and a high-level discharge terminal. It may also incorporate a special filtration system appropriate to the hazardous substance being controlled. Such systems could be required for workshops containing woodworking machinery or large centralised pathology laboratories housing multiple safety cabinets, dissection benches, fume cupboards and specimen stores.
- 7.143 It is important to recognise at the design stage whether an extract is being provided for comfort or as an LEV system. Typical systems in healthcare include:
- microbiological safety cabinets and Category 3 containment rooms;
 - fume cupboards;
 - welding-fume extracts;
 - woodworking machinery duct collectors;
 - battery-charging bay extracts;
 - powered plaster and bone saws;
 - pharmaceutical preparation cabinets and tablet machines;
 - dissection benches, cut-up tables and some specimen stores;
 - medium- and high-risk infectious disease isolation facilities;
 - decontamination facilities;
 - dental furnaces, grinders and polishers.
- 7.144 General design information and guidance for LEV systems is produced by the Health and Safety Executive (HSE) as HS(G)37. Information on the design and installation of microbiological safety cabinets is given in BS5726 and that for fume cupboards is given in BS EN 14175. Their recommendations should be closely followed.
- 7.145 LEV systems are statutory items that will be subject to an independent inspection every 14 months.

Hood extract systems

Special requirements

- 7.146 Extract canopies will be required over steam-and-heat-emitting appliances, for example sterilisers, catering and washing equipment; and for the extraction of toxic fumes over benches used for mixing, sifting and blending procedures.
- 7.147 Perimeter-drain gulley and corrosion-proof grease eliminators should be provided on kitchen hoods.

Typical arrangements

- 7.148 The air-flow rate must be sufficient to ensure an adequate capture velocity in the vicinity of the process; typical values are as follows:
- evaporation of steam and like vapours 0.25 m/s to 0.5 m/s;
 - chemical and solvent releases 1.0 m/s;
 - vapour of gases 5 m/s to 6 m/s;
 - light dusts 7 m/s to 10.0 m/s.

Excessive velocities will be wasteful of power and generate noise.

- 7.149 The lowest edge of the canopy should be 2m above finished floor level, with a minimum of 300mm overhang beyond the edge of the equipment on all sides.
- 7.150 A compact arrangement of equipment (but with access for maintenance) will minimise the canopy area, and hence reduce the air volume necessary to achieve the optimum capture velocity.
- 7.151 Hoods required for the control of heat gain and vapours may be connected to the general extract system when it is convenient to do so, but where non-corrosive ductwork materials are necessary, a separate discharge is preferred.
- 7.152 Lighting and internal divider plates are often required to be built into the perimeter of large canopies. However, built-in shelving systems are not recommended, as they interfere with the air-flow, and constitute a maintenance problem.

Control of hood extracts

- 7.153 Provided that it does not interfere with the operation of the department when not in use, the ventilation system for the hood extract and any associated supply can be shut down. To this end, local control should be provided.

Bench extract systems

Special requirements

- 7.154 Bench extract ventilation is required in departments such as pathology and mortuary, where activities involve the release of malodorous or toxic fumes that should not be inhaled. Where hazardous substances are being controlled, the system should be designated an LEV.

Typical arrangements

- 7.155 Each ventilated position will usually be accommodated in a continuous run of benching, which should not be more than 650mm from front to rear and which should be provided with a continuous upstand at the rear. Each position should have a 1200mm x 150mm linear extract grille mounted on a purpose-designed plenum box (incorporating guide vanes as necessary), with its face flush with the upstand. The bottom of the grille should be as close as practicable to the level of the working surface (usually 75mm above, to allow for cleaning). The minimum velocity across any part of the grille should be 1 m/s. The grille should be readily demountable to allow for cleaning.

Control of bench extract systems

- 7.156 Provided that it does not interfere with the operation of the department when not in use, the ventilation system for the bench extract and any associated make-up supply can be shut down. However, a run-on timer with a minimum setting of 30 minutes must be provided. To this end, local or automatic-use control should be provided.
- 7.157 Processes that produce hazardous vapours, fumes, dusts or noxious vapours should be enclosed or semi-enclosed in a suitable cabinet or exhaust protected workstation.

Safety cabinet and fume-cupboard extract systems

- 7.158 Safety cabinets and fume cupboards are devices that use an inflow of air to control exposure of staff to hazardous substances. The units, their exhaust systems, filters, fans and discharge terminals are all classified as Local Exhaust Ventilation (LEV) systems under the COSHH Regulations. The make-up air system to a room that contains an LEV system should also be considered as an essential part of the system and be included in the LEV classification. Information on the design and installation of microbiological safety cabinets is given in BS5726 and that for fume cupboards is given in BS EN 14175. Their recommendations should be closely followed.
- 7.159 The Advisory Committee on Dangerous Pathogens (ACDP) publishes 'The Management, Design and Operation of Microbiological Containment Laboratories' covering the general environment in which they are used and operational considerations.

Special requirements

- 7.160 The supply-air system should not distort the unidirectional and stable air pattern required for fume cupboards and microbiological safety cabinets. In general, supply-air ceiling diffusers should not discharge directly towards fume cupboards or safety cabinets, unless the terminal velocity is such that the air-flow pattern of the cabinet is unaffected. The design should ensure that high air-change rates, and/or the opening and closing of doors do not have any adverse effect on the performance of safety cabinets or fume cupboards. A damped door-closure mechanism may help.
- 7.161 In order to safeguard the user, all safety cabinets and fume cupboards must be fitted with a clear indication that they are operating correctly. Direct-reading gauges or falling-ball indicators are preferred (in addition to electronic pressure indicators). The system should be set to alarm audibly if the face velocity falls below the minimum safe operating level.

Arrangements for safety cabinet installations

- 7.162 The manufacture and installation of microbiological safety cabinets must be in accordance with the relevant national standards and guidance issued by the Advisory Committee on Dangerous Pathogens (ACDP).
- 7.163 A Class 1 microbiological safety cabinet must be specified for routine work involving Group 3 pathogens. It should be housed in a Category 3 containment room. Specific design information on containment rooms is issued by ACDP in conjunction with the Health and Safety Commission.
- 7.164 Siting and installation of microbiological safety cabinets are of particular importance because:
- the protection afforded to the operator by the cabinet depends on a specific and stable unidirectional air flow through the open front;
 - the protection to the environment by the cabinet depends on the high efficiency particulate air (HEPA) filters. The exhaust air should never be considered as totally free from microbiological hazard.
- 7.165 Microbiological safety cabinet is HEPA filtered prior to being discharged to outside. The extract ductwork should as far as practicable be kept under negative pressure while inside the building.
- 7.166 Current standards permit the installation of microbiological safety cabinets with integral fans, provided that the extract ductwork can be kept short (that is, less than 2m); such an installation however, is likely to be noisy and is not recommended for use in new buildings.
- 7.167 The discharge from the cabinet should be fitted with a back-draft damper. In multiple installations where several cabinets discharge into a common extract and discharge duct, it must be possible to isolate each cabinet from the system when not in use.

7.168 Roof-level discharge, wherever practicable, is preferred since it removes much of the uncertainty over air re-entering the building through ventilation inlets and/or windows. In such an installation, the extract fan should be situated separately from the cabinet and close to the discharge outlet, to maintain the duct within the building under negative pressure. The discharge point on a flat roof should be through a 3m high terminal. This is required to safeguard staff who may need to access the roof periodically for maintenance. This requirement will also be applicable to fume-cupboard discharges.

7.169 Where this is impracticable, discharge into the room via a double HEPA filter has been accepted. The preferred method, however, is to discharge 3m above the roofline in line with the similar standard for fume cupboard designs.

Arrangements for fume cupboard installations

7.170 The manufacture and installation of fume cupboards must be in accordance with the relevant national standards and associated guidance.

7.171 The primary factors that contribute to the effective performance of fume cupboards include:

- an adequate volume of supply air;
- an effective exhaust system to promote the safe dispersal of waste products to atmosphere.

7.172 The air velocities through sash openings must be sufficient to prevent hazardous materials from entering the laboratory while avoiding excess flow rates that interfere with the investigation process. Average face velocities should be between 0.5 and 1.0 m/s, with a minimum at any point within 20% of the average, the upper end of the range being applicable to the containment of materials of high toxicity. The design velocity must be maintained irrespective of whether the sash opening is varied, or whether doors or windows are open or closed. Variable Air Volume (VAV) cupboards are available which offer a reduction in energy use.

7.173 The possibility of a fire or explosion that may not be contained by a fume cupboard must always be considered. A fume cupboard should not, therefore, be sited in a position where exit to an escape route will necessitate passing directly in front of it.

7.174 Fume-cupboard fans should be installed as near as possible to the termination of the duct, thus maintaining the maximum amount of ductwork at negative pressure.

7.175 Where there are adjacent buildings with opening windows, or where downdraughts occur, it may be necessary to increase the height of discharge ducts in order to achieve adequate dispersal. In complex locations, airflow modelling or wind tunnel tests may be required to determine the optimum height of the stack (see also [Paragraph 7.167](#)).

- 7.176 Fume-cupboards for certain processes must have separate extract systems. However, where appropriate, individual fume-cupboard exhaust systems may discharge via non-returning dampers into a single collection duct rather than having a large number of separate stacks. The collection duct should have a large cross-sectional area to minimise its effect on the individual exhaust systems; be open to atmosphere upstream of the first connection; and be designed to discharge a total air volume at least equal to the combined individual extract systems.
- 7.177 Individual fume-cupboard extract systems, discharging either directly to atmosphere or into a collection duct, do not require duplex fans. However, a collection duct designed to provide dispersal of effluent from a number of individual extracts, should have duplex fans with automatic changeover.
- 7.178 Some fumes are particularly corrosive, so the choice of material for the ductwork, and type of extract fan fitted should reflect the nature of the fume being conveyed.

Control of extract systems

- 7.179 It is desirable to provide local control of safety cabinets in order to maximise the life of the HEPA filter, and to permit the sealing of the cabinet and room for fumigation if spillage occurs.
- 7.180 To cope with the risk of an accident or spillage outside safety cabinets, a 'panic button' should be provided to switch off the supply to that area; and discharge all extracted air to atmosphere.
- 7.181 In pathology departments, it will be necessary to have one or more microbiological safety cabinets and one or more fume cupboards available for use at all times, including weekends, therefore, local overriding controls for all these items and any associated ventilation plant will be necessary.

7.0(d) Plantroom ventilation

General requirements

- 7.182 Plant rooms are required to be ventilated in order to maintain acceptable temperatures for satisfactory operation of the plant and controls, and for maintenance activities. In the case of plant rooms housing combustion equipment, a secondary function of the ventilation is to provide make-up air for the combustion process.
- 7.183 The air required for these purposes should be introduced into the space through inlets positioned to minimise the discomfort to occupants; they should be unlikely to be blocked, closed deliberately (except in the case of fire shutters if required), or rendered inoperative by prevailing winds.

- 7.184 Plantroom ventilation air should not be used for any other purposes, such as make-up air for extract; and where the plantroom contains combustion equipment, the appliance pressure must not fall below the outside air pressure.
- 7.185 Specialised healthcare air handling equipment must not be located in a fire compartment that houses combustion equipment.
- 7.186 Statutory regulations for plantroom ventilation are contained in the Scottish Building Regulations, and further guidance is given in CIBSE Guides A & B.

Assessment of ventilation levels

- 7.187 Ventilation requirements must take into account all heat sources within a plantroom, and where there are large glazing areas, solar gains. The ventilation rate should limit the maximum temperature within the plantroom to 32°C.
- 7.188 As the level of equipment operating during mid-season and summer is often lower than the winter condition, and the cooling effect of the outside air is reduced, it is necessary to calculate the minimum volume for each season of operation, and the inlet and outlet grilles or fan sizes should be chosen to cater for the largest seasonal air volume.
- 7.189 Replacement air should not be drawn through pipe trenches or fuel service ducts. Where metal ducts penetrate walls and floors, effective sealing should be provided to confine the ventilation to the boiler room and to meet fire protection requirements. Penetration of fire barrier walls by ventilation ducts should be avoided if possible.
- 7.190 Fire dampers in plant room ventilation ducts should be electrically interlocked with the boiler plant.
- 7.191 Care must be taken to prevent any noise generated in the boiler room emerging from natural or mechanical ventilation openings to the detriment of the surrounding environment. Particular care is necessary with mechanical flue draughts and fan-diluted flue systems.
- 7.192 Information on required air volumes is contained in the CIBSE Guide A & B.
- 7.193 Where combustion plant is installed, the high-level (outlet) openings should be sized to cater for the total ventilating air quantity; and the low-level (supply) openings sized to cater for the total combined ventilating and combustion air quantity.

Choice of ventilation system

- 7.194 Ventilation air may be introduced and exhausted by either natural or mechanical means or a combination of both. However, natural systems are preferred where possible.

- 7.195 Generally, small installations at or above ground level should have their combustion and ventilation air provided by natural means, employing both high- and low-level openings.
- 7.196 Basement, internal and large installations at or above ground level will usually require a combination of natural and mechanical ventilation. If the airflow rate is difficult, both supply and extract may require mechanical means.
- 7.197 Whether natural or mechanical, the system should be designed to avoid both horizontal and vertical temperature gradients. Both inlet and outlet openings should be placed on opposite or adjacent sites of the building to reduce the effect of wind forces.
- 7.198 Where mechanical air supply is employed, electrical interlocks with the boiler plant should be provided to prevent damage in the event of failure of the supply fan(s) once the air volume is established.
- 7.199 The necessary free opening areas for a naturally ventilated plantroom may be calculated using either the method in A4 of the CIBSE Guide A or the table in section B13 of CIBSE Guide B.
- 7.200 A combined natural and mechanical ventilation system should allow for natural extract at high level, to take advantage of convective forces in the room, with mechanical supply at low level. The high level natural ventilators should be sized to cope with the total quantity of ventilation air, as above.
- 7.201 To prevent leakage of flue gases and to ensure that the flue draught is not impeded at any time, the air pressure in the boiler room must not exceed the prevailing outside pressure. Therefore, the fan duty should exceed the calculated total combined combustion and ventilation air quantity by at least 25%. Fan-powered inlets should be arranged to flow outside air into the space at a point where cross-ventilation will ensure pick-up of heat without causing discomfort to occupiers.
- 7.202 Where it is impractical to provide sufficient natural ventilation to remove the heat emitted by the plant, both mechanical supply and extract will be required.
- 7.203 The high-level extract should be sized to cater for the total ventilating air quantity and the low-level supply should exceed the total combined combustion and ventilating air quantity by at least 25%, as above.

7.0(e) Ventilation of hydrotherapy suites

General requirements

- 7.204 In a hydrotherapy suite heat recovery should be via heat pump.
- 7.205 The quantity of supply air should be calculated as 25 litres/sec/m² wetted surface, with the wetted surface taken as 110% of the pool water surface area.
- 7.206 A re-circulation plant is recommended, with a minimum of 20% fresh air.

- 7.207 As far as practicable, re-circulated pool air should be provided to the ancillary changing and recover accommodation, with the only extract from the toilets, laundry/utility room and pool hall.
- 7.208 Supply air to the pool hall should be introduced at high level and directed towards the perimeter to mitigate condensation, with extract air taken from directly over the pool. Dampers should not be located over the pool water.

Control of hydrotherapy pool installations

- 7.209 The supply and extract fans should be interlocked so that the supply fan does not operate until flow is established within the extract system.
- 7.210 Time-clock control should be provided, with a local override switch to extend the normal operating period as required.
- 7.211 Night setback temperature (in the range of 21°C -25°C) and high humidity control (in the range of 60-75% sat) should be provided to override the time clock in order to prevent condensation. The exact set points should be ascertained post-installation.
- 7.212 A remote indication panel should be provided in the pool hall, giving a visual display of the pool water and pool air temperature.

8. Validation of specialised ventilation systems

Definitions

Commissioning - Commissioning is the process of advancing a system from physical completion to an operating condition. It will normally be carried out by specialist commissioning contractors working in conjunction with equipment suppliers. Commissioning will normally be the responsibility of the main or mechanical services contractor.

Validation - A process of proving that the system is fit for purpose and achieves the operating performance originally specified. It will normally be a condition of contract that *“The system will be acceptable to the client if at the time of validation it is considered fit for purpose and will only require routine maintenance in order to remain so for its projected life.”*

Note: Commissioning is often sub divided into sections e.g. air handling unit, automatic controls, airside balance, building fabric and fittings. Each section may be commissioned by its specialist installer and they are often accepted in isolation. Validation differs from commissioning in that its purpose is to look at the complete installation from air intake to extract discharge and assess its fitness for purpose as a whole. This involves examining the fabric of the building being served by the system and inspecting the ventilation equipment fitted as well as measuring the actual ventilation performance.

It is unlikely that ‘in house’ staff will possess the knowledge or equipment necessary to validate critical ventilation systems such as those serving operating suites, pharmacy clean rooms and local exhaust ventilation systems. Validation of these systems should therefore be carried out by a suitably qualified independent Authorised Person appointed by the Health Board.

It is anticipated that training in the validation of specialised healthcare ventilation systems for independent Authorised Persons will become available during the life of this SHTM.

Commissioning general

- 8.1 Commissioning is an essential process for ventilation systems. It is therefore important that adequate provision for the process be made at the design stage of the project. Procedures for commissioning air-handling systems are given in CIBSE Commissioning Codes and BSRIA Application Guide Set COMPAK 1.
- 8.2 The duct-sizing procedure should take into account the requirements of system balancing, and the position and number of regulating dampers included in the design should be sufficient for this purpose.

Location of dampers and test holes

- 8.3 Balancing/commissioning dampers will be required in each branch of the distribution ductwork.
- 8.4 Test holes for the measurement of air-flow will be required at carefully selected points in main and all branch ducts. The number and spacing of holes are given in the BSRIA Application Guide Set COMPAK 1. Their positions must be identified at the design stage.
- 8.5 The test positions need to be accessible for commissioning to take place. They may also be required for subsequent annual verification of the system performance, so they should not be covered by permanent lagging.
- 8.6 The measurement point should be in a straight length of duct as far away as possible from any upstream bends, dampers or other elements that could cause disturbance to the airflow. The actual location should be:
- at least 1.5 duct diameters upstream of sources of turbulence such as dampers and bends;
 - if this is not possible, 10 diameters downstream of dampers, bends or tees, and 5 diameters downstream of eccentric reducers;
 - where there is enough space round the duct to insert the pitot tube and take readings;
 - where the duct has a constant cross-sectional area.
- 8.7 Test holes for measuring total airflow from a fan should be located either 4 diameters upstream or 10 diameters downstream of the fan. Provision should also be made for measuring the speed of rotation.

Information to be provided

- 8.8 It is essential that the designer should pass on his intentions fully to the commissioning engineer by indicating which parts of the system are high, medium and low pressure, and by providing:
- relevant parts of the specification;
 - schematic drawings indicating performance data as indicated in [Table 8](#);
 - equipment schedules;
 - controller and regulator schedule;
 - fan performance curves;
 - wiring diagrams for electrical equipment, including interlock details.

Items in system	Information to be provided
Fans	Fan total pressure Volume flow rate at high and low speed Maximum motor current
Plant items	Type and identification numbers from equipment schedules Fluid and air volume flow rates Fluid and air side pressure losses Dry bulb temperatures Wet bulb temperatures Humidity
Dampers, including motorised and fire dampers	Identification numbers from equipment schedules Location Identification number Volume flow rate
Main and branch ducts	Dimensions Volume flow rates and velocities Identification numbers from equipment schedules
Terminal	Location Identification number Grille or diffuser factor Volume flow rate and neck velocity Operating static pressure
Test holes and access panels	Location Identification number
Controllers	Set points

Table 8: Information to be provided on schematic drawings

Notes: For Table 8

1. Fan total pressure is the difference between the total pressure (static pressure + velocity pressure) at the fan outlet and the total pressure at the fan inlet.
2. Where volume flow rates are variable, maximum and minimum values should be provided.

Commissioning personnel

8.9

As one individual is unlikely to possess all of the required commissioning skills, a commissioning team is therefore usually needed. The objective of commissioning is to ensure that the necessary performance and safety requirements are met.

- 8.10 During the commissioning process a great deal of information will be generated which will form an invaluable future source of reference about the plant. It is essential to ensure that it is collected together in the form of a commissioning manual and handed over to the client on completion of the contract together with the ‘as fitted’ drawings. This information should be both in hard copy and electronic format.
- 8.11 In order to be successful the commissioning process must start before achieving practical completion as many parts of the system will become progressively less accessible. The correct installation of those parts will need to be witnessed and leak-rate tests carried out as construction proceeds. Failure to establish responsibility for commissioning early enough will delay the completion of the project or lead to unsatisfactory plant performance.

Commissioning brief

- 8.12 The commissioning team will require a detailed brief from the system designer. This should include:
- a ‘user’ brief comprising a description of the installation and its intended mode of operation;
 - the precise design requirements with regard to the scheme of air movement, room static pressures, supply and extract air-flow rates and acceptable tolerances;
 - full details of the design conditions both inside and out, for winter and summer together with the control strategy;
 - equipment manufacturer’s type test data, commissioning, operation and maintenance recommendations;
 - drawings showing the layout of the system, positions of air-flow measurement test points, dampers, regulating devices and filters within the duct runs, together with sizes of ducts and terminal fittings. It will save time if these drawings are annotated with the design volumes and static pressures required at each branch and outlet point;
 - wiring diagrams for all electrical equipment associated with the air handling systems including motor control circuit details and any interlocking and safety devices such as emergency-stop buttons adjacent to the item of plant.
- 8.13 The CIBSE Commissioning Code, Series ‘A’ – “Air Distribution”, provides full guidance on the information that will be required by the commissioning team.
- 8.14 The designer should include in the contract document instructions on verifying the accuracy of test instruments that should be supported by reference to relevant calibration certificates.
- 8.15 The system, on completion, should be operated by the contractor as a whole and subject to performance tests in accordance with the contract requirements.

For critical systems, these may include independent validation of the system performance on behalf of the client.

- 8.16 Prior to dynamic commissioning, it is essential that builders' work in the area served by the system is complete, all rubbish and dust is removed, concealed plumbing (IPS-type) panels are in position and ceiling tiles are in place and clipped. Floors should be mopped and visible dust removed from all other surfaces.
- 8.17 Once the system is shown to meet the design intent the handover documentation should be completed. In the event of performance not being acceptable, the matter should be dealt with in accordance with the contract arrangements.

Pre-commissioning checks

- 8.18 The pre-commissioning checks consist of visual inspection, manual operation of equipment, static measurements and functional tests of individual components. They should be carried out prior to setting the system to work and undertaking the dynamic commissioning process set out in [Paragraph 8.29](#) onwards of this guidance.

Standard of installation

- 8.19 During the installation of the system the following must be witnessed:
- that the plant and installations have been provided and installed in accordance with the design specification and drawings;
 - that only approved sealants have been used in the installation;
 - that all components function correctly;
 - that the satisfactory sealing of access doors and viewing ports have been carried out;
 - that air pressure tests and air-leakage tests on ventilation ducting have been carried out in accordance with the methods set out in the HVCA's DW/143: Ductwork Leakage Testing. It is usual to carry out these tests, a section at a time, as the ductwork is installed and before its insulation is applied. The results must be recorded in the commissioning manual;
 - that gaps around doors and hatches are as specified in the design;
 - that the correct operation of pressure stabilisers, control dampers, isolating and non-return dampers have been checked and installed in the correct orientation for air-flow;
 - that test holes have been provided in their specified locations and are sealed with suitable grommets;
 - that control dampers are secured and their quadrants fitted correctly;
 - that any interlocks are operative and in accordance with specification;

- that the electric circuits are completed, tested and energised;
- that electric motors have been checked for correct direction of rotation both at full speed and set-back;
- that cooling and heating media are available at correct temperatures and pressures and in specified quantities;
- that the air-conditioning plant components and controls function correctly;
- that the air-conditioning plant interlocks and safety controls function correctly;
- that the plant is physically complete, insulation is applied and all ducts and pipework are identified as specified;
- that the building housing the ventilation plant is generally in a fit condition for commissioning and performance tests to commence, that is, windows, doors, partitions etc are completed, surfaces sealed and their final finish applied;
- that the areas containing the ventilation plant and those being served by it are clean;
- that access to all parts of the system is safe and satisfactory.

Cleanliness of installation

- 8.20 During installation it must be established that ductwork is being installed to the ‘advanced level’ as defined in the HVCA (2005) ‘TR/19 – Guide to good practice: internal cleanliness of ventilation systems’. This specifically includes ensuring that ductwork sections arrive on site and are stored with their open ends sealed and that open ends remain sealed during installation to prevent the ingress of builders’ dust.
- 8.21 Should any doubt exist whether the guidance has been observed, the ducts must be cleaned internally to restore them to this standard before being taken into use.
- 8.22 “Builders work” ducts of brick or concrete must be surface sealed to prevent the release of dust before being taken into use.
- 8.23 The area around the supply air intake must be free of vegetation, waste, rubbish, builders’ debris or any other possible source of contamination.

Certification of equipment

- 8.24 The following test certificates should be assembled by the commissioning team and be available for inspection at any time during the contract period. They will form part of the handover information and should be placed in the commissioning manual:
- type-test performance certificates for fans;
 - pressure-test certificates for:

- heater-batteries;
- cooling coils;
- humidifiers (if appropriate);
- type-test certificates for attenuators;
- type-test certificates for primary and secondary filters;
- individual test certificates for high efficiency particulate air (HEPA) filters.

Equipment tests

8.25 Prior to setting the system to work, the checks in [Paragraphs 8.26 - 8.28](#) should be witnessed, and proving tests should be carried out as detailed.

Filters

8.26 The quality of filter housing and in particular, the seals is a critical factor in maintaining the efficacy of the filtration system by ensuring that air does not bypass the filter panels. Therefore, the following checks should be made:

- filter seals should be fitted and in good condition;
- filters should be installed correctly with respect to air flow;
- bag filters should be installed so that the bags are vertical and their pockets free;
- HEPA filters should be installed in a sealed housing and their seals tested to DIN 1946 if specified;
- all filters should be checked to ensure they are free of visible damage;
- the differential pressure indicators should be checked for accuracy and that they are marked with the initial and final filter resistance.

Drainage arrangements

8.27 The drain should conform in all respects to the “Design considerations” of this SHTM. In addition the following must be proved:

- that the drain tray is easily removable;
- that a clear trap is fitted and is easily removable;
- that the drain has a clear air gap of at least 15mm;
- that the pipework is supported so that the air break cannot be reduced;
- that the drain system from each drain tray is independent up to the air break;
- that the operation of the drainage system is proved by introducing water into the duct at the drain tray and observing that it completely drains out. This check is to be repeated both at normal speed and set back once the fans

have been commissioned. At this time the clear trap can be marked to indicate the normal water level with the fan running.

Fire dampers

- 8.28 The following must be witnessed and proving tests should be carried out as detailed:
- the operation of all fire dampers;
 - the access provided to enable the dampers' to be visually inspected and / or re-set should be sufficient for the purpose;
 - indication should be provided of the dampers' position (open/tripped);
 - indication of the fire dampers' location should be provided both on the ductwork and at a visible point on the building fabric if the ductwork is concealed.

Dynamic commissioning

Air-handling and distribution system

- 8.29 The fan drive, direction of rotation, speed and current drawn should be set in accordance with their manufacturer's instructions.
- 8.30 After the installation has been checked to ensure that it is in a satisfactory and safe condition for start-up, it should be set to work and regulated to enable the plant to meet its design specification. The proportional balancing method described in the CIBSE Commissioning Code "A" must be followed. The air-flow rates must be set within the tolerances laid down in the design brief. This will normally be the design airflow rate +10% -0%.
- 8.31 When combined supply and extract systems are to be balanced and the area that they serve is to be at or above atmospheric pressure then the supply should be balanced first with the extract fan switched off, and then the extract balanced with the supply fan(s) on.
- 8.32 For combined systems where the area that they serve is to be below atmospheric pressure then the extract should be balanced first with the supply fan switched off and then the supply balanced with the extract fan on.
- 8.33 On completion of the balance all volume air-flows in supply and extract ducts and from grilles and diffusers must be measured and recorded. The true air change rate can then be calculated from the data obtained.
- 8.34 The main supply and extract duct volume control dampers must be locked and their position marked.
- 8.35 All grille and diffuser volume control registers must be locked to prevent alteration and their final position marked.

Room air distribution

- 8.36 The pressure-relief dampers and pressure stabilisers must be set to achieve the specified room static pressures and locked. The grille direction control vanes and diffuser cones must be set to give the specified air-movement pattern. Visualisation techniques may need to be employed in order to prove that the required air-flow pattern is being achieved. This may be a potential requirement when commissioning LEV systems or rooms that contain them.

Air-conditioning plant

- 8.37 The specified flow rate and/or pressure drops must be set for all heater batteries, cooling coils and humidifiers. The methods described in the CIBSE Commissioning Codes “W” and “R” should be followed. On completion their regulating devices must be locked to prevent alteration.

Control system

- 8.38 The control system should not be commissioned until both the air distribution system and air-conditioning equipment have been commissioned.
- 8.39 Because of the specialised nature of control systems and the fact that each manufacturer’s system will contain its own specialist components and settings, the commissioning should be completed by the supplier and witnessed by a representative of the user.
- 8.40 The location of all control and monitoring sensors should be checked and their accuracy proved.
- 8.41 The control system’s ability to carry out its specified functions must be proved.
- 8.42 If the plant is provided with a “user’s” control panel in addition to the one located in the plantroom then the operation of both must be proved. This will typically apply to operating departments and laboratory systems.

Specific performance standards

Air movement

- 8.43 The performance of the system should be measured and compared with information provided by the designer.

Plant capacity and control

- 8.44 When setting to work and proving the design, both the manufacturer of the air-handling plant and the control specialist should attend site together and jointly commission the system.
- 8.45 If any doubt exists as to the capacity of the installed system, then its ability to achieve the specified inside design conditions with the plant operating at winter

and summer outside design conditions must be proved. Artificial loads will be required in order to simulate the internal gains/losses and the outside design conditions.

- 8.46 On completion of the plant performance test, recording thermo-hygrographs should be placed in each room/area served by the plant and also the supply air duct upstream of the frost battery. The plant should be run for 24 hours with all doors closed. During this period the inside conditions must stay within the tolerances specified. The BEMS should be used to obtain the information required wherever possible. Periodic tests will be required during the defects liability period.

Noise levels - general

- 8.47 The commissioning noise level is the level measured with a sound-level meter in the unoccupied room and taking account of the external noise together with the noise generated by the ventilation system. When occupied and in use this commissioning level will constitute a continuous background noise that will allow the overall noise level to be achieved. The ventilation plant design noise level is that generated by the plant alone with no other noise source being considered. The levels suggested make recognised allowance for the ingress of environmental noise.
- 8.48 The noise levels apply at the maximum velocity for which the system is designed to operate. Acoustic commissioning tests should be carried out with all plant and machinery running normally and achieving the design conditions of airflow, temperature and humidity.
- 8.49 An industrial-grade sound-level meter to BS 3489 or IEC 651 Type 2 will normally be sufficient to check the noise level.
- 8.50 The noise level readings are to be taken at typical normal listening position 1.5m above floor level and at least 1m from any surface and not on any line of symmetry. In critical rooms the noise should be measured at the centre of the room and at the centre of each quarter. The mean of the 5 readings should then be calculated.
- 8.51 In the event of a contractual deficiency, a Type 1 precision-grade sound-level meter should be used and the noise level determined by the procedure given in Scottish Health Technical Memorandum 08-01 (2011).

Filter challenge

General ventilation filters

- 8.52 In-situ performance tests will not normally be required for primary and secondary filters and their housings. However the filters should be visually inspected for grade, tears, orientation and fit within their housing. Filters should be clean and a replacement set available. Bag filters should be installed so that

their bags are vertical and spaced so that air can move through them freely. Any filter found to be wet should be replaced and the cause investigated.

HEPA filters (for exhaust protective enclosures and laboratories)

- 8.53 Pathogenic material may be discharged through damaged or badly installed HEPA terminal filters. The complete installation must be tested using the method set out in BS EN: 14644 'Method of Testing for the Determination of Filter Installation Leaks'.
- 8.54 The challenge tests may be carried out using either of the following techniques:
- use Dispersed Oil Generator (DOP) to provide the challenge and a photometer to detect leaks;
 - use a Discrete Particle Counter (DPC) to detect leaks. (In order to obtain a sufficient challenge it may be necessary to remove temporarily the supply AHU secondary filters).
- 8.55 In both cases the upstream challenge should be measured. A measurement of particle penetration through a representative section of the HEPA filter media is then taken and used as the reference background level. These two readings enable the range of the detecting instrument to be set.
- 8.56 A challenge aerosol of inert particles of the type produced by a DOP generator should be introduced into the air, upstream of the HEPA filter. The downstream face of the filter, its mounting seal and housing would then be scanned for leakage using a photometer. A leak should be deemed to have occurred if a steady and repeatable reading on the photometer at any point exceeds 0.01% of the upstream reading.
- 8.57 Alternatively a Discrete Particle Counter (DPC) may be used. For the Discrete Particle Counter method the filter face is sampled at several points to establish the smallest non-penetrating particle size. If particles at or above this size are detected when subsequent scans of the filter face, its seal and housing are made, then there is deemed to be a significant leak at, or near, the test position.
- 8.58 Should the HEPA filter fail this test it must be replaced. Should the filter mounting seal or housing fail this test it may be repaired and the test repeated.

Bacteriological sampling

General ventilation systems

- 8.59 Bacteriological sampling will not normally be required for either general or local exhaust ventilation (LEV) systems unless otherwise specified.

Conventional operating rooms

- 8.60 The level of airborne bacteria introduced by the supply air can be checked by closing all doors and leaving the operating room empty with the ventilation system running for 15 minutes. An active air sampler set to 1 cubic metre and mounted on the operating table should then be activated remotely. Aerobic cultures on non-selective media should not exceed 10 bacterial and/or fungal colony forming units per cubic metre (CFU/m³).
- 8.61 The results should be examined to establish the broad category of organisms present. A high preponderance of fungal organisms may be an indication of inadequate filtration for the particular installation. Precise guidance is inappropriate and will depend on local circumstances.
- 8.62 It may be appropriate to carry out a check of airborne bacteria during a surgical operation. If required this should be carried out as soon as possible after handover. Unless there are unusually high numbers of personnel or extensive activity in the room, the number of airborne bacterial and/or fungal CFU averaged over any five-minute period, would be unlikely to exceed 180 per cubic metre.
- 8.63 Information on the additional validation testing of UCV Operating suites is given in [Section 8.0\(a\)](#).

Ventilation system commissioning/validation report

- 8.64 Following commissioning and/or validation a full report detailing the findings should be produced. The system will only be acceptable to the client if at the time of validation it is considered fit for purpose and will only require routine maintenance in order to remain so for its projected life.
- 8.65 The report shall conclude with a clear statement as to whether the ventilation system achieved or did not achieve the required standard. A copy of the report should be lodged with the following groups:
- the user department;
 - infection control (where required);
 - estates and facilities.

8.0(a) Validation of UCV operating suites

General

- 8.66 Commissioning of a UCV terminal will normally be carried out by its supplier. Commissioning of the air-handling unit, fire dampers, distribution ductwork and control systems may be undertaken by different teams. It is therefore important to recognise that the UCV terminal is only one element of the specialised ventilation system serving the operating suite and it cannot be accepted in isolation.

- 8.67 In order to ensure that the complete system operates correctly it will be necessary to validate the system as a whole from the air intake through to the extract discharge. It is unlikely that “in house” staff will possess the knowledge or equipment necessary to undertake this process. Validation of Ultra-Clean operating theatre ventilation systems should therefore be carried out by a suitably qualified independent Authorised Person appointed by the client.
- 8.68 It is anticipated that training in the validation of specialised healthcare ventilation systems for independent Authorised Persons will become available during the life of this SHTM.
- 8.69 The following regime of inspection and testing should be applied to the validation of new installations designed to provide Ultra-Clean conditions in an Operating suite. The test regime has been devised to ensure that the system as installed fully achieves the design requirement for these systems as set out in [Section 7.0\(b\)](#) of this document.

Basic requirement

- 8.70 The operating suite to be validated should be physically complete with final finishes applied. All ventilation systems serving it should be operating correctly and delivering the design air-flow rates.
- 8.71 In order to avoid pre-loading the UCV terminal’s recirculation ducts and HEPA filters, the Operating suite should be free of any obvious dust and at least “builders clean” before the recirculation fans are set to work.
- 8.72 The validation procedure for a conventional theatre suite should have been satisfactorily completed to the standard set out in [Section 8](#) prior to attempting to validate the UCV unit. In particular:
- the supply AHU will have achieved the minimum standard;
 - the operation of all fire dampers will have been proved;
 - the supply and extract air-flow rates as measured in ducts and at room terminals will achieve their design values +10%; -0%;
 - room differential pressures will be correct.

Evidence of the satisfactory achievement of the foregoing standard should be available for inspection and independently measured as necessary *prior to validating the UCV unit.*

UCV unit validation procedure

- 8.73 Tests to validate the suitability and performance of an ultra-clean operating suite should be undertaken in the order that they appear below. Should an item fail to meet the required standard it should be rectified and successfully retested before passing on to the next test.

Summary of test regime

- Challenge tests to ensure that:
 - the UCV terminal unit is correctly assembled and sealed so that no air will bypass the filters;
 - the terminal filters are correctly sealed in their housings;
 - the terminal filters are of the same grade, of uniform quality and undamaged.
- Air velocity measurements to ensure that
 - a sufficient quantity of air is being delivered by the terminal;
 - the terminal quadrants are in balance;
 - the air flow has sufficient velocity to reach the working plane.
- An entrainment test to ensure that contaminants arising outside of the UCV terminal footprint are not drawn into it.
- Visualisation techniques to gain an understanding of the overall system performance.
- Noise measurement to ensure that working conditions are satisfactory.
- Control system checks to ensure that the system operates as specified.
- Biological monitoring to determine how effective the system is in use.

Test and measuring conditions

8.74 While validating the UCV terminal, the conditions in the Operating room shall be stable and within the given ranges.

temperature: – 19°C - 23°C dry bulb.

humidity: – 30 – 65% relative humidity.

Test and measuring equipment

8.75 Any test or measuring equipment used should have a certificate to prove that it has been validated within the previous 12 months at a calibration facility using traceable national standards.

8.76 In the case of a noise meter, its “matched sound source” should have a certificate to prove that it has been validated within the previous 12 months at a calibration facility using traceable national standards. The noise meter should be calibrated to the sound source on each occasion that it is used.

Test grid – vertical units

8.77 A test grid should be constructed on the floor within the ultra-clean terminal footprint as projected by the inside dimensions of the sidewalls or boundary air

curtain. A suitably marked test sheet will provide a consistent standard of test grid.

- 8.78 The test grid should comprise test squares of 280mm each side.
- 8.79 The test grid should be aligned along the centre lines of the terminal footprint with its centre under the centre point of the terminal.
- 8.80 Any test square with 80% of its area within the UCV footprint should be used as a test position.
- 8.81 An inner zone should be designated that is not less than 36% of the total footprint. It should be made up of a number of test squares distributed symmetrically about the terminal footprint centre line. Regardless of the shape of the terminal footprint, the inner zone should comprise a minimum grid of 6 x 6 test squares.
- 8.82 Unless specified otherwise, a test position should be in the geometric centre of a test square.
- 8.83 Test position 1 should be the leftmost test square in the row nearest to the operating room wall that houses the surgeon’s panel.

(For an example of a grid for a 2.8 x 2.8 metre terminal see [Figure 8](#))

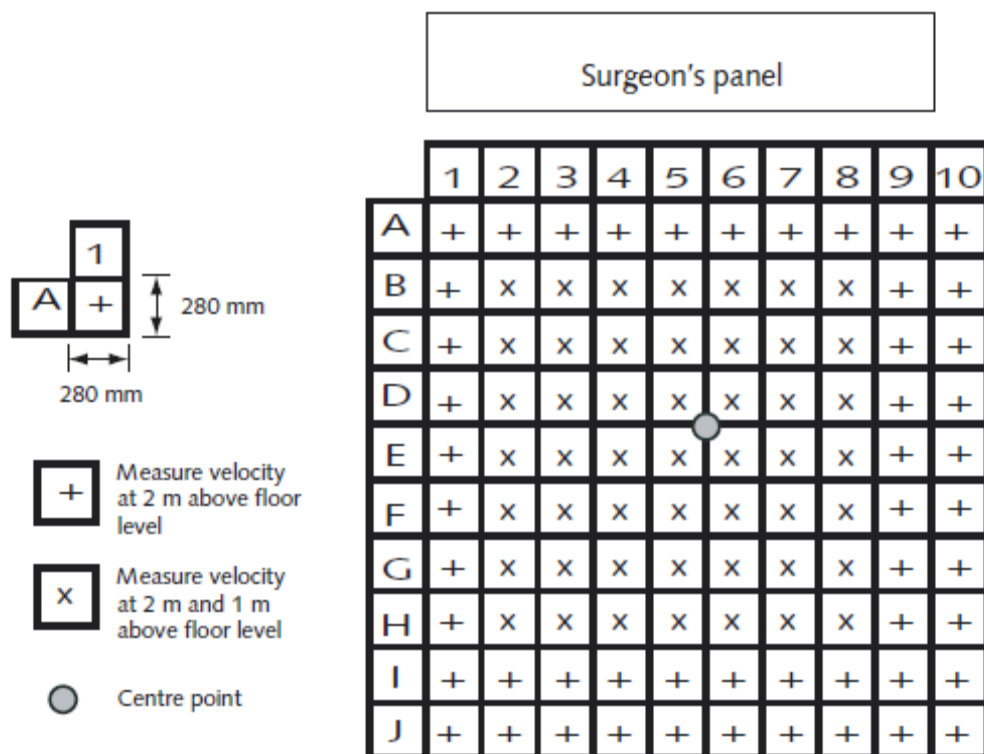

Figure 8: Example of a Test Grid for a 2.8m x 2.8m UCV Terminal

Test grid – horizontal units

- 8.84 A line of test positions should be marked on the floor 1m in front of the face of the UCV terminal.

8.85 A test position should be marked in the centre of the line. Additional test positions should be marked at 280mm spacing along the line either side of the centre position, up to the full-face width of the unit.

UCV terminal challenge tests (Vertical and horizontal systems)

8.86 The diffuser screen fitted below the face of the terminal HEPA filters should be lowered or removed while the challenge tests are being carried out.

8.87 The installed HEPA filters should be checked to ensure that their grade accords with the design specification and that their performance has been certified by the manufacturer.

8.88 The challenge tests may be carried out using either of the following techniques:

- use DOP to provide the challenge and a photometer to detect leaks;
- use a DPC to detect leaks. In order to obtain a sufficient challenge it may be necessary to remove temporarily the supply AHU secondary filters.

8.89 In both cases the upstream challenge should be measured. A measurement of particle penetration through a representative section of the HEPA filter media is then taken and used as the reference background level. These two readings enable the range of the detecting instrument to be set.

8.90 For the DOP test this should be set as the reference level and a leak will be declared significant if penetration greater than 0.01% of the range is detected. (See [Paragraph 8.56](#) for details).

8.91 For the DPC method the filter face is scanned to establish the smallest non-penetrating particle size. If significant particles at or above this size are detected when subsequent scans are made then there is deemed to be a significant leak at, or near, the test position. (See [Paragraph 8.57](#) for details)

UCV terminal unit clean zone leak test

8.92 This test will confirm that there is no unfiltered air bypassing the HEPA filter.

8.93 The joints and service penetration points under the UCV terminal within its side walls or boundary air curtain should be scanned to prove that there are no leaks.

8.94 A leak is defined as a significant rise above the background level.

Terminal HEPA filter seal leak test

8.95 The test will confirm that there is no unfiltered air bypassing the HEPA filter's seal.

8.96 Each HEPA filter's seal should be scanned to prove that there are no leaks.

8.97 A leak is defined as a significant rise above the background level.

Terminal HEPA filter media leak test

- 8.98 The test will confirm that the HEPA filters have not sustained damage while being installed.
- 8.99 The face of each HEPA filter should be scanned to prove that there are no leaks.
- 8.100 A leak is defined as a significant rise above the background level.

Vertical UCV terminal air velocity tests

Test set up

- 8.101 The terminal face diffuser screen should be in place for these tests.
- 8.102 Take spot readings to establish that the room is within the specified temperature and humidity test conditions.
- 8.103 Set out the test grid as described previously.
- 8.104 Swing the operating lamp arms and any other stem arms so that they align to present the least resistance to air flow, are perpendicular to the front edge of the test sheet and face the back edge. Any lamp and equipment heads should as far as practicable be outside of the UCV terminal footprint.

Test instrument

- 8.105 The measuring instrument should be a hot-wire anemometer with a digital read-out. The instrument resolution should be at least 0.01m/s, have a tolerance of ± 0.015 m/s or 3% of that reading and be calibrated down to 0.15 m/s or lower. An alternative instrument may be used providing it is of no lesser specification.

Test method

- 8.106 The instrument should be mounted on a test stand and set to take a mean reading over a ten-second sample interval.
- 8.107 It is recommended that a printer be linked to the test instrument so that readings are recorded automatically. Alternatively they could be downloaded to a computer or data logger at the end of the test.
- 8.108 The test stand to be positioned on each test point in turn and the reading taken when the instrument has stabilised.
- 8.109 When taking a reading the test person should not stand within the same quadrant as the test instrument.
- 8.110 Readings are to be taken at the test positions with the instrument probe facing the wall housing the surgeon's panel, commencing at the first test position.

Readings are taken working along the row from left to right and back, or for all text positions in one quadrant at a time.

- 8.111 When all test positions under one half of the terminal have been covered, readings of temperature and humidity are then taken at the specified height in the centre of the terminal. The read-outs on the surgeon's panel should be recorded at the same time.
- 8.112 Having completed one half of the test grid, the operating lamp arms and any other stem arms should be swung round through 180° and the test stand reversed so that the wall housing the surgeon's panel is behind the test person. Readings are recommenced starting at the right of the test row and working from right to left a quadrant at a time, as above.

UCV high-level discharge velocity test

- 8.113 Measurements of air velocity are to be taken at every test position 2m above floor level and the results averaged.
- 8.114 The average of the total readings taken is to be not less than:
0.38 m/s for a partial-wall system;
0.30 m/s for a full-wall system.

The average air velocity for each quadrant should not exceed $\pm 6\%$ of the measured average velocity for the terminal

UCV low-level air velocity test

- 8.115 Measurements of air velocity are to be taken at each of the inner zone test position 1m above floor level.
- 8.116 The measured velocity at every test position in the inner (operating) zone shall be not less than 0.2 m/s.

Horizontal UCV terminal air velocity test

Test set up

- 8.117 Set out the line of test positions as described previously.
- 8.118 Swing the operating lamp arms and any other stem arms so that they align to present the least resistance to air flow and are perpendicular to the line of test positions.

Test instrument

- 8.119 See that specified for vertical systems ([Paragraph 8.105](#) refers).

Test method

- 8.120 The instrument should be mounted on a test stand and set to take a mean reading over a ten-second sample interval.
- 8.121 It is recommended that a printer be linked to the test instrument so that readings are recorded automatically. Alternatively, they could be downloaded to a computer or data-logger at the end of the test.
- 8.122 The test stand should be positioned on each test point in turn and the reading taken when the instrument has stabilised.
- 8.123 When taking readings the test person should stand well downstream of the instrument.
- 8.124 Readings are to be taken at the test positions with the instrument probe facing the UCV terminal, commencing at the first test position on the left and working along the row from left to right at the specified height.
- 8.125 The instrument should be reset to the next specified height and the test repeated and so on.
- 8.126 Readings of temperature and humidity should be taken at the specified height in the centre of the terminal. The read-outs on the surgeon's panel should be recorded at the same time.

UCV discharge velocity test

- 8.127 Measurements of air velocity are to be taken at all test positions at 1m, 1.5m and 2m above floor level.
- 8.128 The average of the total readings taken should be no less than 0.4 m/s.

UCV entrainment test (Vertical systems only)

Rationale for the entrainment test

- 8.129 The performance of UCV systems may be compromised by room air being drawn into the ultra-clean airflow, a phenomenon known as “entrainment.” Significant levels of entrainment could lead to microbial contamination of items left exposed on instrument trolleys laid out beneath the canopy.
- 8.130 UCV systems having permanently fitted full sidewalls do not need to be tested, as the sidewalls physically prevent entrainment.

Principle of the test

- 8.131 A source of particles is produced outside of the UCV terminal and is used to challenge the system. A detector is placed within the ultra-clean airflow and used to determine the percentage penetration of the test particles at predefined

locations under the UCV terminal footprint. The source and detector are moved in tandem around the UCV canopy and pairs of readings taken, from which the percentage penetration at specified locations is calculated. The degree of penetration should be below specified maximum limits if entrainment is to be declared not significant.

- 8.132 The entrainment test may be carried out using either of the following techniques:
- use DOPs to provide the challenge source at the specified release position and a photometer to measure the entrainment; or
 - duct non-HEPA-filtered air to the specified release position and use a DPC to measure the entrainment.

Test set-up

- 8.133 The terminal face diffuser screen should be in place for these tests.
- 8.134 The test should be performed without any equipment in place beneath or closely adjacent to the UCV terminal.
- 8.135 The theatre lights should be moved to a central position beneath the terminal and raised to 2m above floor level, so as not to interfere with the peripheral airflows.
- 8.136 Take spot readings at the centre of the canopy, one metre from floor level, to establish that the room is within the specified temperature and humidity test conditions.
- 8.137 Set out the test grid as described previously.
- 8.138 For either of the following entrainment tests, a measurement of particle penetration through a representative section of the HEPA filter media is to be taken and used as the reference background level.

Test equipment, challenge source, measuring instrument and detector head

- 8.139 The challenge and detector equipment should be chosen so that:
- the tracer particles are mainly within the size range 0.3 to 5 microns and thus capable of remaining airborne for a substantial time;
 - the particles used should not be able to penetrate the terminal filters in sufficient numbers to cause a background count that is more than 0.1% of the challenge count;
 - the choice of particle and detector will enable a minimum of a three-logarithm (1,000-fold) range of counts to be recorded between the highest (that is, source) and lowest (that is, background) readings expected. (A concentration of approximately 10^5 particles per cubic metre of source air has been shown to be adequate.)

Source – Dispersed Oil Particles (D.O.P.)

- 8.140 The DOP generator should be able to produce a cloud of test particles in the form of a visible smoke. The test smoke should be delivered via an aperture so that it flows vertically downward from the lowermost edge of the partial wall, on the outside of the UCV canopy.
- 8.141 The test smoke is to be delivered via an aperture.

Note 4: To prevent undue contamination of the theatre and filters with deposits of oil, DOP should only be released for the minimum amount of time necessary to complete the test.

Challenge source – natural particles

- 8.142 The source unit should be a fan/blower or other method that takes non-HEPA-filtered air and expels it via a delivery head at the specified release position to provide the particle challenge. The challenge air should be delivered vertically downwards from the lowermost edge of the partial wall, on the outside of the UCV canopy, parallel to the airflow coming from the diffusers. The challenge air velocity should be the same as the measured average velocity at 2m from the terminal under test.

Note 5: The use of DOP for testing is gradually being phased out and replaced by a natural challenge measured with a DPC. At the time of writing research is under way to define more precisely a challenge source unit for natural particles. It is anticipated that such a unit, together with a matching test methodology, will become available during the life of this Scottish Health Technical Memorandum.

The detector (defined in terms of range and resolution)

- 8.143 This may be a photometer or a DPC. It is recommended that a printer be linked to the test instrument so that readings are recorded automatically. The instrument should be capable of sampling a minimum a 28.3 litres of air per minute and in the case of the DPC, provide readings for particle size ranges from 0.3 microns to 5.0 microns and greater. The instrument should be compliant with the requirements of BS EN ISO 14644-1. An alternative instrument may be used providing it is of no lesser specification.

Test positions and orientation of source and detector

- 8.144 The test positions should be at the centre of each test square, as defined for the velocity test.
- 8.145 For rectangular UCV terminals, measurements of penetration are to be taken at the four corner test squares of the test grid and at intermediate positions along the line of test squares between the corners. The number of intermediate test positions will be as equally spaced as possible around the periphery with no fewer than 3 and no more than 5 complete test squares between test positions.

- 8.146 A further series of measurements are to be obtained around the periphery of the inner zone. Measurements of penetration are to be taken at the four corner test squares of the inner zone of the test grid and if necessary at intermediate positions along the line of test squares between the corners as equally spaced as possible, with no fewer than 3 and no more than 5 complete test squares between test positions.
- 8.147 A single measurement should be taken at the geometrical centre of the UCV terminal footprint. The centre measurement will be taken with the detector head mounted vertically upwards 1 metre above floor level.
- 8.148 The centre of the challenge particle source should be aligned with the centre of the designated test square, with its longer edge against the outer edge of the partial wall and delivering the challenge from the lower edge of the partial wall. The air containing challenge particles is directed vertically downwards from the lower edge of the partial wall, in a plane parallel to the adjacent partial wall. Where there is physical interference due to obstructions such as gas pendants, the source will be moved to the next available non-obstructed test-square location nearest to the stipulated sampling position. The detector should then also be moved to remain opposite the source.
- 8.149 In the case of non-rectangular terminals, an interpretation of the above strategy should be adopted that will yield a no less searching examination of the unit's ability to control entrainment.

Test method

- 8.150 The sampling head of the detector instrument is mounted on a test stand with its sampling orifice facing outwards horizontally from the centre of the UCV canopy, 1m above floor level. The sampling head should be orientated at right angles to the partial wall when sampling along the sides of the test grid but will be set to bisect the angle when measuring at the corner test positions (Figure 88 illustrates the challenge and detector orientations when evaluating a 2.8m x 2.8m UCV terminal).
- 8.151 The test will commence at the first test position, this being designated the leftmost corner of the test grid when facing the wall housing the surgeon's panel. The penetration will also be measured at the corresponding test point on the inner zone commencing at the corner nearest to the first test position. When these tests have been completed, the source and detector equipment should be moved to the next test positions, working around the test grid in a clockwise direction.
- 8.152 The test stand should be positioned on each test point in turn and a pair of readings (challenge, then penetration) taken when the instrument has stabilised. The detector should be set to take a reading over a 15 second sample interval.
- 8.153 When taking a reading the test person should stand within the UCV terminal footprint but not in the same quadrant as the detector head.

Analysis and interpretation

8.154 The following standard is to be achieved:

- penetration to be not greater than 10% of the challenge at each test position in the outer zone;
- penetration to be no greater than 1% of the challenge at each test position in the inner zone;
- penetration to be no greater than 0.1% of the challenge at the centre of the test grid.

If a result is close to, or above the given limits, then a further reading must be obtained using a longer time base (1 minute) and the penetration must not exceed the given limit.

Basis of the test

8.155 Whyte W, Shaw BH, Freeman MAR. An evaluation of a partial-walled laminar-flow operating room. *J Hyg Camb* 1974; 73: 61 – 75.

Whyte W, Lidwell OM, Lowbury EJJ, Blowers R. Suggested bacteriological standards for air in ultraclean operating rooms. *J Hosp Infect* 1983; 4: 133 – 139.

UCV visualisation

8.156 The use of smoke to gain an understanding of the overall performance of the system may prove useful at this stage in the validation process but cannot be relied on to produce a contractually definitive measure of performance.

UCV noise level

8.157 An industrial-grade sound-level meter to BS EN 61672 Type 2 fitted with a muff should be used to check the noise level. The instrument should be calibrated using a matched sound source prior to each set of readings.

Vertical systems

8.158 The noise level readings should be taken at typical normal listening positions 1.5m above floor level and at least 1m from any surface and not on any line of symmetry. Measurements should be taken under the centre of each quadrant of the UCV terminal and the four readings averaged.

Horizontal systems

8.159 The noise level readings are to be taken at typical normal listening positions 1.5m above floor level on the test line. The width of the unit should be divided

in two and a measurement taken in the centre of each half but avoiding any line of symmetry. The two readings should be averaged.

- 8.160 Measurements should also be taken in each room of the suite.
- 8.161 In the event of a contractual deficiency a Type 1 precision-grade sound-level meter complying with BS EN 61672 should be used. Readings should be taken at the positions specified above and in each case the logarithmic mean of the results should be calculated in order to determine the noise level. Further information can be found in SHTM 08-01 (2011).
- 8.162 For vertical or horizontal systems, the noise level shall not exceed:
- 50NR [55dB(A)] – for UCV operating rooms and spaces without doors that open directly on to it (for example the scrub);
 - 40NR [45dB(A)] – for all other peripheral rooms of the suite.

UCV control system checks

Temperature

- 8.163 The readings of temperature taken under or in front of the UCV unit should be within ± 1 K of each other and the read-out on the surgeon's panel.

Humidity

- 8.164 The readings of humidity taken under or in front of the UCV unit should be within $\pm 5\%$ of each other and the read-out on the surgeon's panel.

Direct-reading differential pressure gauges

- 8.165 The differential pressure across the terminal filter(s) should be measured to confirm the accuracy of the indicated reading of any gauge.

Control functions

- 8.166 The operation of all control functions provided on the surgeon's panel should be proved for conformity with the design specification.
- 8.167 If an auxiliary panel has been fitted then its interlocking with the main surgeon's panel control functions must be proved to conform to the design specification.

Panel indicator lights

- 8.168 The panel indicator lights should illuminate as appropriate when the control functions are selected or warning levels are reached

BEMS interface

- 8.169 The operation, monitoring and alarm functions must be proved to conform to those set out in the design specification.

UCV theatre microbiological tests

- 8.170 There is little value in performing microbiological sampling in a new theatre supplied with ultra-clean ventilation. The foregoing filter challenge tests, air velocity measurements and entrainment test should have proved that the system operates satisfactorily and achieves the contracted level of performance. The HEPA filters will remove bacteria-sized particles from the air supplied through the UCV terminal. Therefore there will be an insignificant number of bacterial and/or fungal CFUs present until the Theatre is actually used.
- 8.171 Once the theatre has been taken into use, microbial sampling during a surgical procedure should help to confirm the satisfactory performance of the system and discipline of the users. Before commencing bacteriological testing, the room and its ventilation system should have achieved a steady state condition: (see also [Paragraph 8.74](#))
- 8.172 The installation should be tested during surgical procedure at intervals between the time of the first incision and final closure of the wound. On average, the air sampled within 300mm of the wound should not contain more than 10 CFU/m³.

UCV validation report

- 8.173 Following validation a full report detailing the findings should be produced. The report shall conclude with a clear statement as to whether the UCV theatre suite achieved or did not achieve the standard set out above.
- 8.174 A copy of the report should be lodged with the following groups:
- operating department;
 - infection control;
 - estates and facilities.

Appendix 1: Table A1: Recommended air-change rates

Application	Ventilation	ac/Hour	Pressure (Pascals)	Supply Filter	Noise (NR)	Temp (°C)	Comments For further information see Section 6
General ward	S / N	6	-	G4	30	18-28	
Communal ward toilet	E	10	-ve	-	40	-	
Single room	S / E / N	6	0 or -ve	G4	30	18-28	
Single room WC	E	3	-ve	-	40	-	
Clean utility	S	6	+ve	G4	40	18-28	
Dirty utility	E	6	-ve	-	40	-	
Ward Isolation room	-	-	-	-	-	-	See SHPN 4; Supplement 1
Infectious disease Iso room	E	10	-5	G4	30	18-28	Extract filtration may be required
Neutropenic patient ward	S	10	+10	H12	30	18-28	
Critical Care Areas	S	10	+10	F7	30	18-25	Isolation room may be -ve press
Birthing Room	S & E	15	-ve	G4	40	18-25	Provide clean air-flow path
SCBU	S	6	+ve	F7	30	18-25	Isolation room may be -ve press
Preparation room (Lay-up)	S	>25	35	F7*	40	18-25	*H12 if a lay-up for a UCV Theatre
Preparation room / bay sterile pack store	S	10	25	F7	40	18-25	*50NR if a bay in a UCV Theatre
Operating theatre	S	25	25	F7	40	18-25	
UCV Operating theatre	S	25*	25	H12	40	18-25	Fresh air rate; excludes re-circulation
Anaesthetic room	S & E	15	>10	F7	40	18-25	Provide clean air-flow path
Theatre Sluice/dirty utility	E	>20	-5	-	40	-	
Recovery room	S & E	15	0	F7	35	18-25	Provide clean air-flow path

Table A1

Application	Ventilation	ac/Hour	Pressure (Pascals)	Supply Filter	Noise (NR)	Temp (°C)	Comments For further information see Section 6
Recovery room	S & E	15	0	F7	35	18-25	Provide clean air-flow path
Cardiac catheterisation lab	S	15	+ve	F7	40	18-22	
Endoscopy room	S	15	+ve	F7	40	18-25	
Endoscopy cleaning	E	>10	-ve	-	40	-	
Day case theatre	S	15	+ve	F7	40	18-25	
Treatment room	S	10	+ve	F7	35	18-25	
Pharmacy aseptic suite	S	20	#	H14	-	18-22	# See EGGMP (Orange guide) a
Cat 3 or 4 containment room	#	>20	#	H14*	-	18-22	# See ACDP guide; *Filter in extract
Post mortem room	S & E	S = 10 E = 12	-ve	G4	35	18–22	Provide clean air-flow path
Specimen store	E	-	-ve	-	-	-	Fan accessible from outside of store

Table A1 continued

Notes: 18°C-22°C indicates the range over which the temperature may float

18°C-22°C indicates the range over which the temperature should be capable of being controlled

S = supply

N = natural ventilation

E = extract ^a – European guidelines on good manufacturing practice published by the Medicines and Healthcare products Regulatory Authority (MHRA)

Appendix 2: Hierarchy of cleanliness

Class	Room	Nominal pressure (Pa) a	Air-flow rate for bacterial contaminant dilution	
			Flow in or supply m ³ /s	Flow out or extract m ³ /s
Sterile	Preparation room		See standard schemes in Appendix 3 for recommended design values	
	(a) lay-up	35		
	(b) sterile pack store	25		
	Operating room	25		
	Scrub bay b	25		
Clean	Sterile pack bulk store	+ve	6 ac/h	-
	Anaesthetic room c	14 c	The greater of 15 ac/hr or 0.15	The greater of 15 ac/hr or 0.15
	Scrub room	14	-	0.10
Transitional	Recovery room	3	15 ac/hr d	15 ac/hr d
	Clean corridor	0	e	7 ac/hr
	General access corridor	0	e	7 ac/hr
	Changing rooms	3	7 ac/hr	7 ac/hr
	Plaster room	3	7 ac/hr	7 ac/hr
Dirty	Service corridor	0	-	f
	Disposal room	-5 or 0	-	0.41 or 0.10

Table A2

Notes (applicable to Table A2):

- a. Nominal room pressures are given to facilitate setting up of pressure relief dampers, the calculation process, and the sizing of transfer devices. In practice, the resultant pressures are not critical, provided the desired airflow rates and movement are achieved.
- b. An open or semi-open bay is considered to be part of the operating room; provided air movement is satisfactory, no specific extract is required. However if the layout means that air movement is poor, a local extract may be required to control local condensation on the building surfaces, which can result in mould growth.
- c. For design purposes, anaesthetic should be assumed to be at 14 Pa. When commissioning 10 Pa is considered suitable.
- d. 15 ac/hr are considered necessary for the control of anaesthetic gas pollution.
- e. Supply airflow rate necessary to make up 7 ac/hr after taking into account secondary air from cleaner areas.
- f. No dilution requirement. Temperature control requirements only.

Type	Pressure difference - Pa						
	5	10	15	20	25	30	40
Single door (CDB Size 2.4.3.2.6.)	.03	.05	.06	.06	.07	.07	.08
Double door (CDB)	.04	.08	.10	.11	.12	.13	.14
High permanent length of 3mm gap	.004	.008	.010	.011	.012	.012	.013

Table A3: Leakage flows in m³/s through closed door gaps

Note: CDB = Component Data Base

It should be noted that many doors are now fitted with cold smoke seals as standard. These will significantly reduce the door leakage rate when new and undamaged. It is therefore recommended that provision for the design leakage is factored into the sizing of the appropriate transfer grille or pressure stabiliser. Failure to do this will result in air gap whistles and doors being held partially open by air pressure.

Factory-assembled door-sets with a steel frame and pre-hung leaves have become common. There is effectively no leakage across these doors when closed. Therefore, when this type of door assembly is fitted, the door leakage can be ignored and the design airflow into the room reduced accordingly. The design airflow would then become that required either (i) for open door

protection, or (ii) to achieve the specified air-change rate - whichever is the greater.

Room class		Dirty	Transitional	Clean	Sterile
Sterile	Hatch	0.3	0.24	0.18	
	Single door	0.47	0.39	0.28	0 or 0.28 a
	Double door	0.95	0.75	0.57	0 or 0.57 a
Clean	Single door	0.39	0.28	0 or 0.28 a	
	Double door	0.75	0.57	0 or 0.57 a	
Transitional	Single door	0.28	0 or 0.28 a		
	Double door	0.57	0 or 0.57 a		
Dirty	Single door	0	Open single door = 0.80m x 2.01m high		
	Double door	0	Open double door = 1.80m x 2.01m high		

Table A4: Recommended air flow rates in m³/s through a doorway between rooms of different cleanliness to control cross-contamination

Designer’s Notes:

- a. The degree of protection required at an open doorway between rooms is dependent upon the degree of difference in cleanliness between them.
- b. Flow rate required between rooms within the same class tends to zero as class reduces.
- c. If two rooms are of equal cleanliness, no flow is required (in practice there will be an interchange in either direction) and the design of the air movement will assume zero air-flow. In certain cases, however, interchange is not permitted and protection airflow of 0.28 is assumed in the design, for example, in the case of a preparation room used as a “lay up”.

		Effect on other rooms	
Door open between	Resultant pressure in these rooms (Pa)	Room	Pressure (Pa)
Operating room and corridor or Scrub bay and corridor	0	Anaesthetic	0
		Preparation – lay up	12
		Disposal	-6
		Preparation – sterile pack store	5
Operating room and anaesthetic room (or other series room with double doors)	17	Preparation – lay up	26
		Disposal	-9
		Preparation – sterile pack store	22
Operating room and disposal room or Operating room and preparation room	25	No change	
Anaesthetic room and corridor (or other series room with double doors)	0	Preparation – lay-up	30
		Disposal	-6
		Operating room	20
		Preparation – sterile pack store	25
Preparation room – corridor Disposal room & corridor	0	No change	
Disposal room & outer corridor	0	No change	

Table A5: Typical pressures in an operating suite when a given door is open

Notes: 1. The room differential pressure protects against reverse flows when the door is closed.

2. The flow of air through a doorway protects against reverse airflow when the door is open.

3. Pressure stabilisers control flow and ensure a known air-flow path between rooms when doors are closed and reduce back-flow between rooms when doors to other rooms are open.

Appendix 3: Operating suite design logic

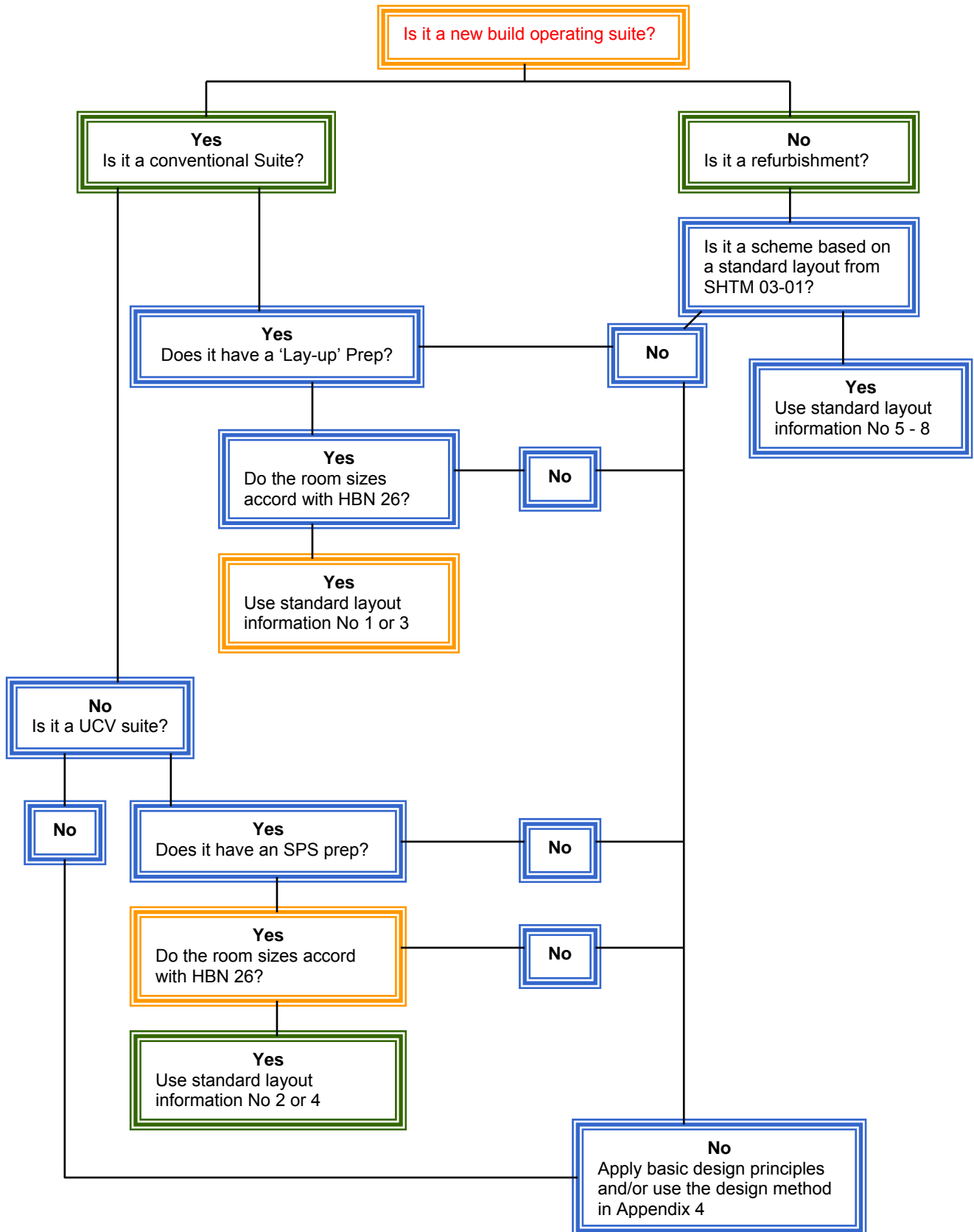

New Standard Layout N° 1 - Suitable for a typical conventional theatre suite (Room sizes as specified in HBN 26)

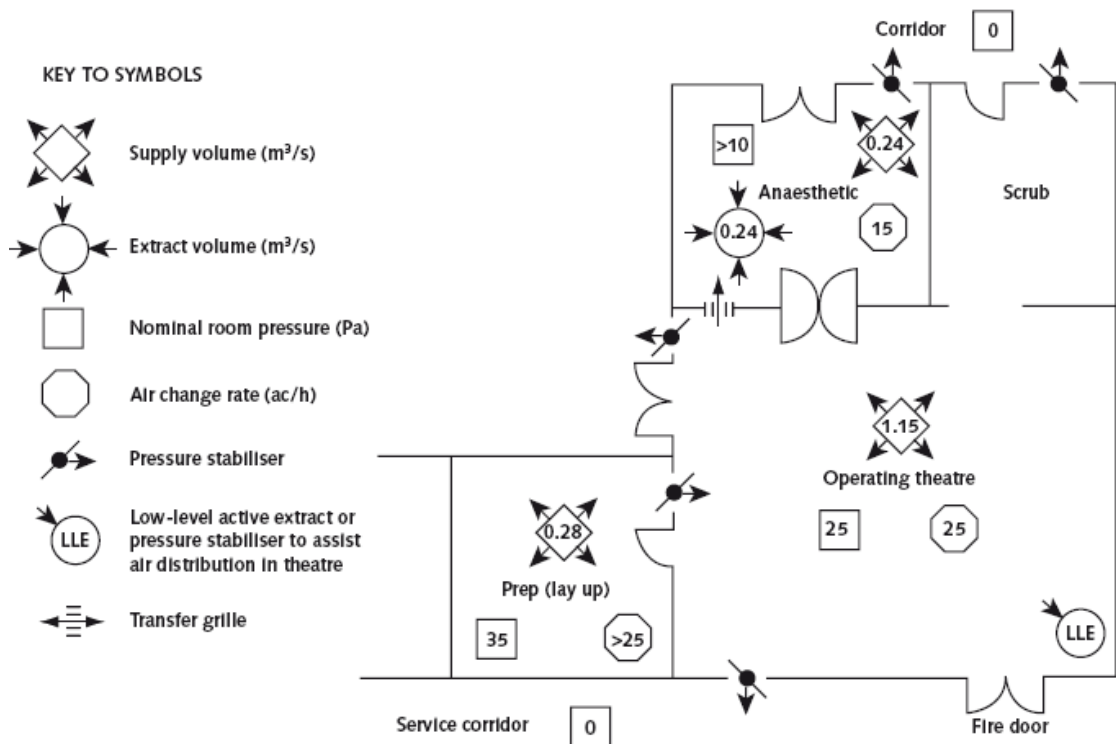

Room	Size m ³ <small>Derived from HBN26</small>	Air-Change Rate per hour	Nominal Pressure Pa	Flowrate m ³ /s
Theatre	165	25	25	1.15
Anaesthetic	57	15	>10	0.24
Lay-Up-Prep	36	>25	35	0.28**
Scrub	*	-	25	-

*This is a separate scrub and is not considered as being part of the theatre volume.

**Interchange is not permitted between the theatre and lay-up prep; therefore an airflow protection of 0.28 + 0.06 closed-door airflow is required as a minimum.

The volume of air to be extracted from the theatre should be determined by subtracting the airflow required for door protection at the exits from the total air entering the theatre space. The balance should be equally divided between the passive or active extract locations.

The extracts within the theatre may be either passive and fitted with pressure stabilizers or active and connected to the extract system. They should be

located at low level and positioned to promote the ventilation of all areas of the space.

New standard layout N° 2 - Suitable for a typical UCV theatre suite (Room sizes as specified in HBN 26)

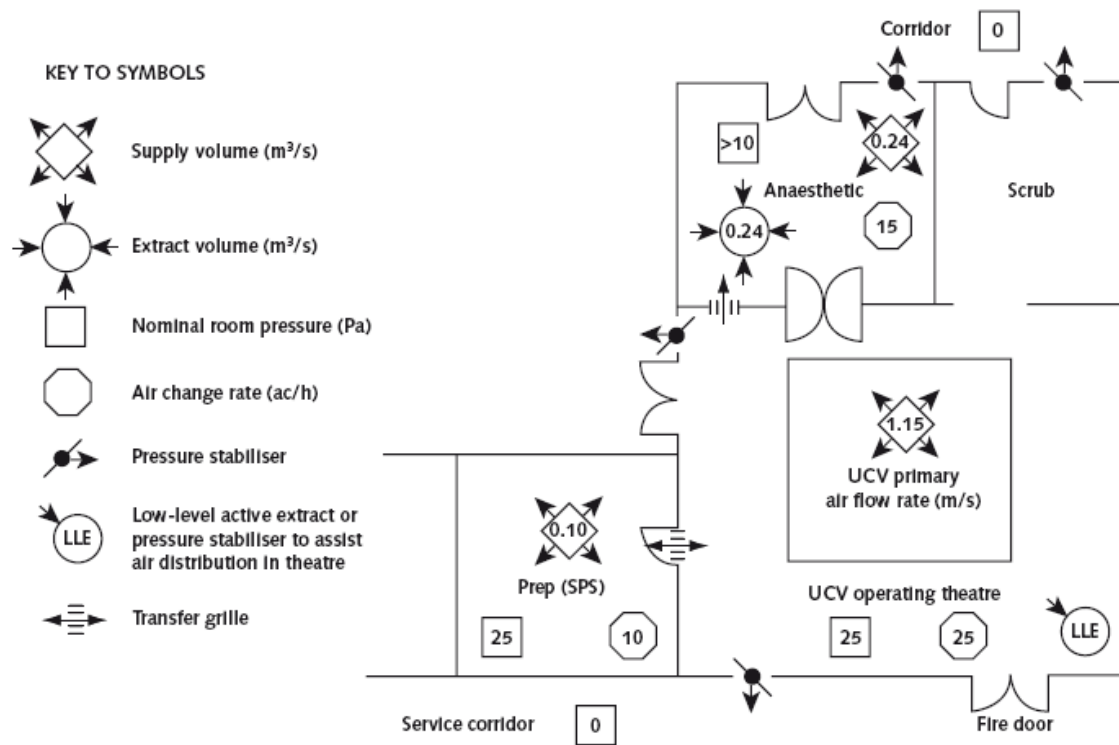

Room	Size m ³ <i>Derived from HBN26</i>	Air Change Rate per hour	Nominal Pressure Pa	Flowrate m ³ /s
Theatre	165	25	25	1.15**
Anaesthetic	57	15	>10	0.24
Sterile Prep	36	25	25	0.10
Scrub	*	-	25	-

*Separate scrub and not considered as part of theatre volume

**Primary Fresh air Volume Only

The volume of air to be extracted from the theatre should be determined by subtracting the airflow required for door protection at the exits from the total air entering the theatre space. The balance should be equally divided between the passive or active extract locations.

The extracts within the theatre may be either passive and fitted with pressure stabilizers or active and connected to the extract system. They should be located at low level and positioned to promote the ventilation of all areas of the space.

New standard layout N° 3 - Suitable for a typical Conventional theatre suite (Layout and room sizes are as illustrated in HBN 26)

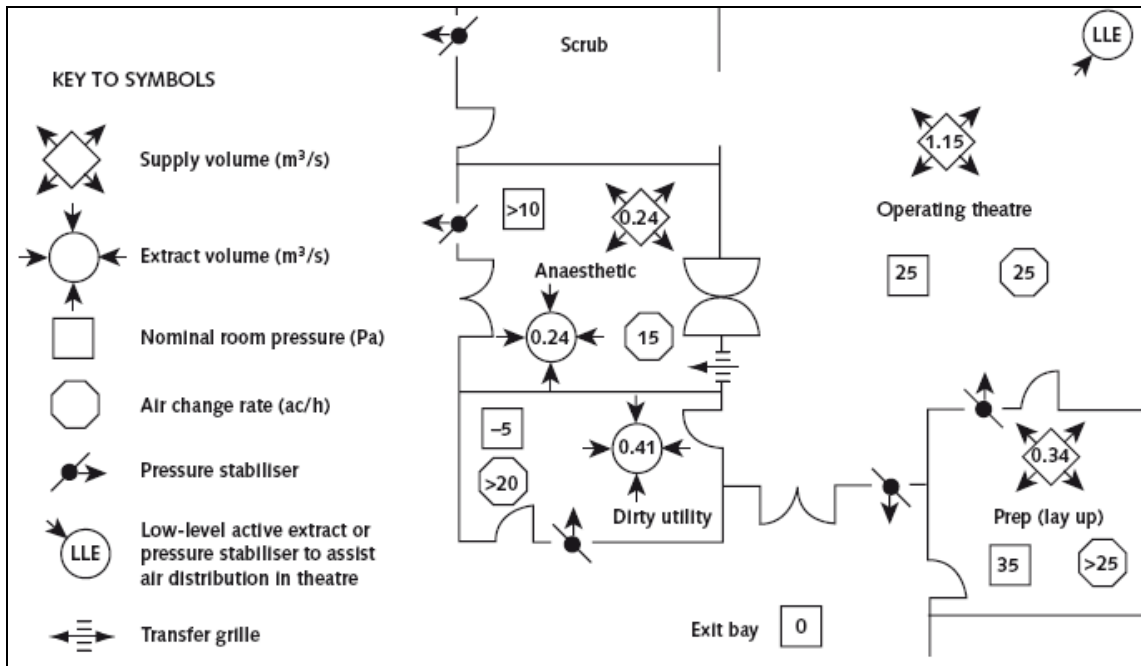

Room	Size m ³ <small>Derived from HBN26</small>	Air Change Rate per hour	Nominal Pressure Pa	Flowrate m ³ /s
Theatre	165	25	25	1.15
Anaesthetic	57	15	14	0.24
Lay-Up Prep	36	>25	35	0.34**
Scrub	*	-	25	-
Dirty Utility	36	-	-5	0.41

*Separate scrub not considered part of theatre volume.

**Interchange is not permitted between the theatre and lay up prep therefore as Table 4 an airflow protection of 0.28 + 0.06 closed door air flow is required as a minimum.

The volume of air to be extracted from the theatre should be determined by subtracting the airflow required for door protection at the exits from the total air entering the theatre space. The balance should be equally divided between the passive or active extract locations.

The extracts within the theatre may be either passive and fitted with pressure stabilizers or active and connected to the extract system. They should be located at low level and positioned to promote the ventilation of all areas of the space.

New standard layout N° 4 - Suitable for a typical UCV theatre suite (Layout and room sizes are as illustrated in HBN 26)

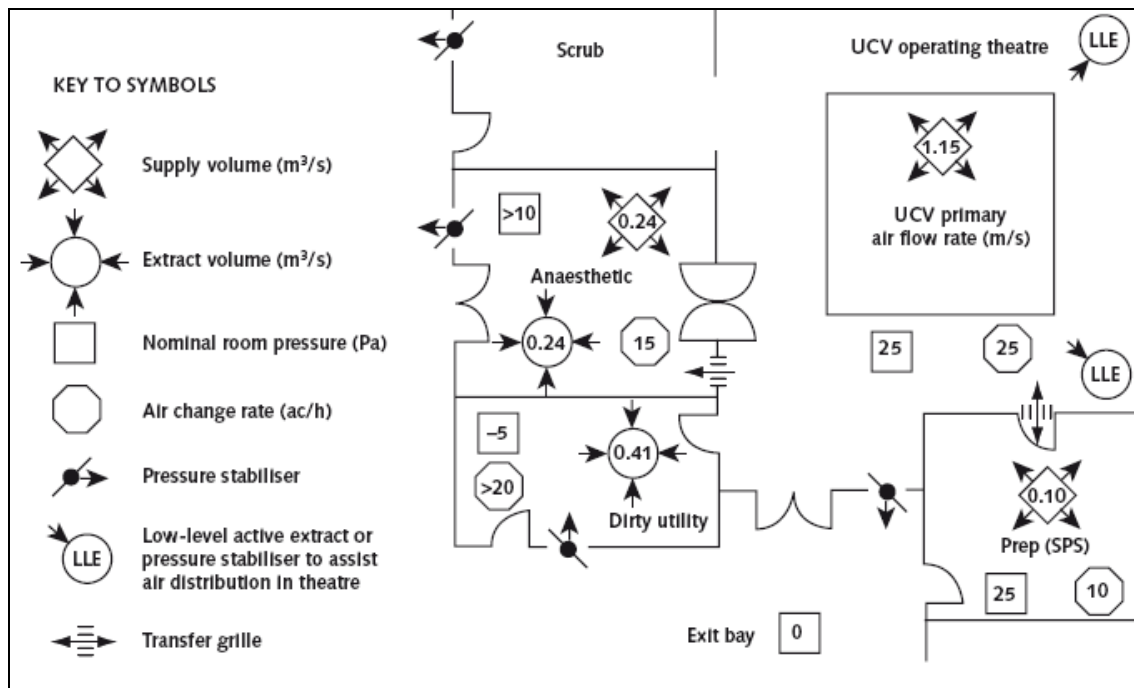

Room	Size m ³ Derived from HBN26	Air Change Rate per hour	Nominal Pressure Pa	Flowrate m ³ /s
Theatre	165	25	25	1.15**
Anaesthetic	57	15	>10	0.24
Sterile Pack Prep	36	10	25	0.10
Scrub	*	-	25	-
Dirty Utility	36	-	-5	0.41

* Separate scrub not considered part of theatre volume

**Primary Fresh air Volume Only

The volume of air to be extracted from the theatre should be determined by subtracting the airflow required for door protection at the exits from the total air entering the theatre space. The balance should be equally divided between the passive or active extract locations.

The extracts within the theatre may be either passive and fitted with pressure stabilizers or active and connected to the extract system. They should be located at low level and positioned to promote the ventilation of all areas of the space.

New standard layout N° 5 - SHTM 2025 Existing standard plan '1b' typical layout for a conventional theatre suite

This layout and data is for historical purposes only. The information is to be used for the evaluating of existing systems or rebalancing following ventilation system cleaning.

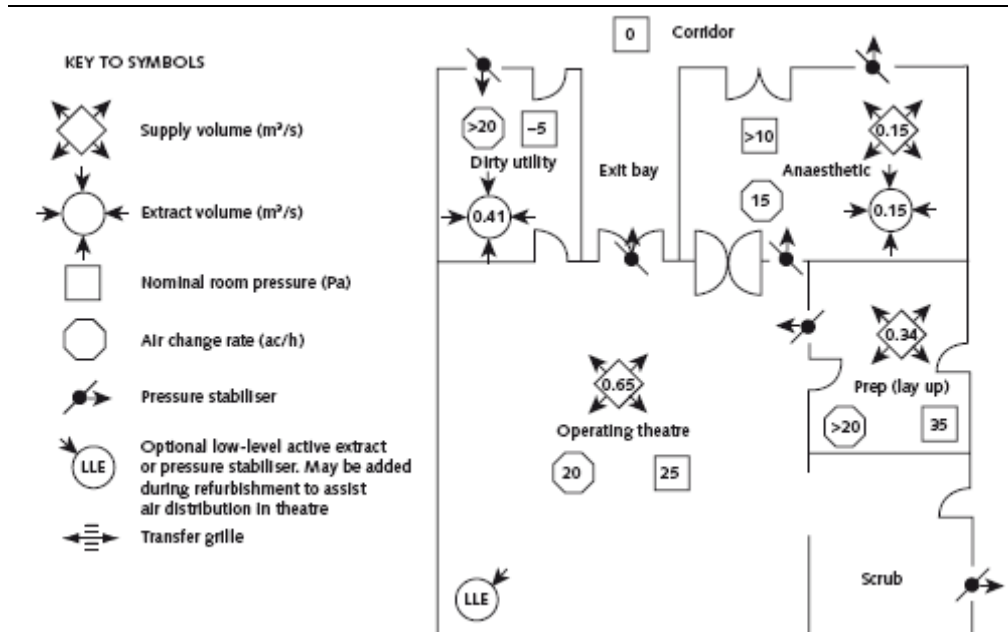

Room	Size m ³	Air Change Rate per hour	Nominal Pressure Pa	Flowrate m ³ /s
Theatre	Existing Theatre Suite to Be measured on site	20	25	0.65
Anaesthetic		15	14	0.15
Lay-Up Prep		-	35	0.34
Scrub		-	25	Included within theatre
Disposal		-	-5	0.41

The disposal layout detailed will remain the same should a hatch be utilised instead of a door onto the outer corridor.

Standard layout No 6 - SHTM 2025 Existing standard Plan '1a' Typical layout for a UCV theatre suite

This layout and data is for historical purposes only. The information is to be used for the evaluating of existing systems or rebalancing following ventilation system cleaning.

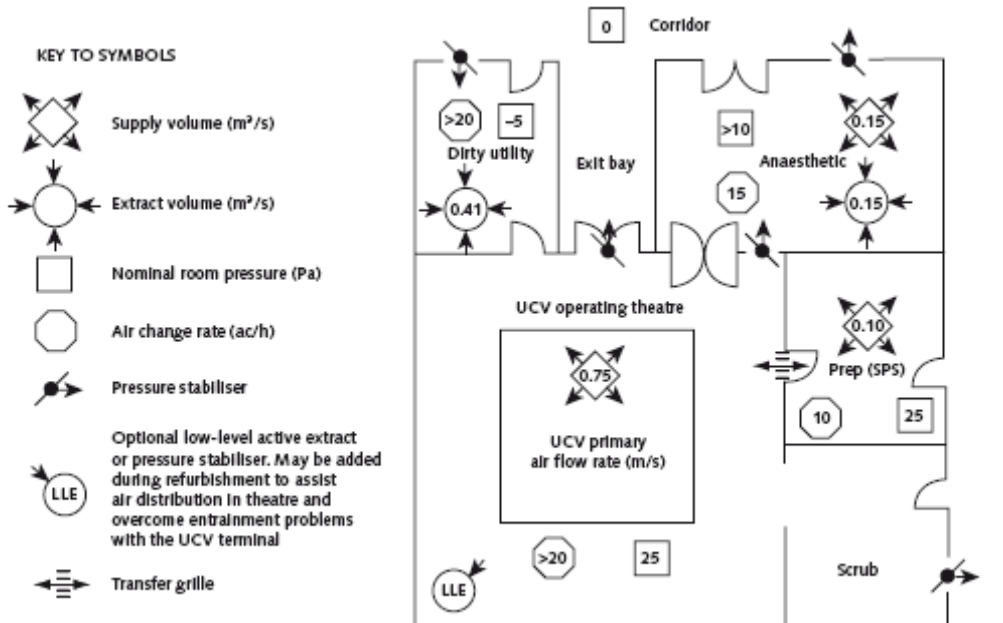

Room	Size m ³	Air Change Rate per hour	Nominal Pressure Pa	Flowrate m ³ /s
Theatre	Existing Theatre Suite to be measured on site	20	25	0.75*
Anaesthetic		15	>10	0.15
Sterile Pack Prep		10	25	0.1
Scrub		-	25	Included within theatre
Disposal		-	-5	0.41

*Primary fresh airflow volume

The disposal layout detailed will remain the same should a hatch be utilised instead of a door onto the outer corridor.

Standard layout N° 7 - SHTM 2025 Existing standard Plan '5b' Typical layout for a conventional theatre suite

This layout and data is for historical purposes only. The information is to be used for the evaluating of existing systems or rebalancing following ventilation system cleaning.

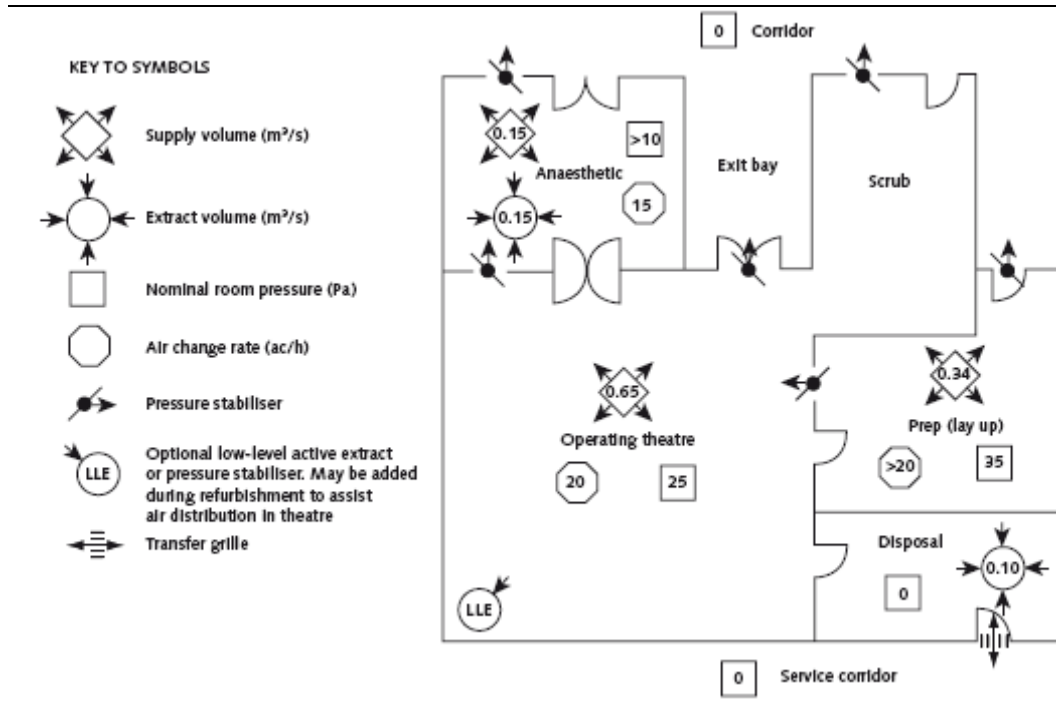

Room	Size m ³	Air Change Rate per hour	Nominal Pressure Pa	Flowrate m ³ /s
Theatre	Existing Theatre Suite to be measured on site	20	25	0.65
Anaesthetic		15	>10	0.15
Lay-Up Prep		>20	35	0.34
Scrub		-	25	Included within theatre
Disposal		-	0	0.1

The disposal layout detailed will remain the same should a hatch be utilised instead of a door onto the outer corridor. Alternatively the disposal room could be omitted and replaced with a disposal hatch between the theatre and corridor.

Standard layout N° 8 - SHTM 2025 Existing standard Plan '5a' Typical layout for a UCV theatre suite

This layout and data is for historical purposes only. The information is to be used for the evaluating of existing systems or rebalancing following ventilation system cleaning.

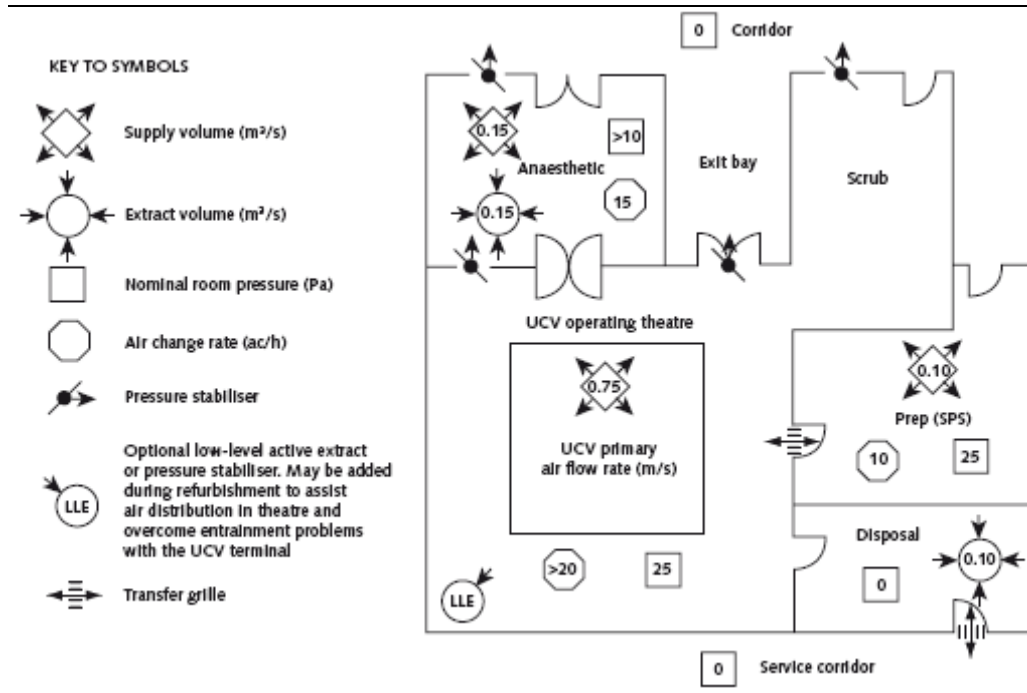

Room	Size m ³	Air Change Rate per hour	Nominal Pressure Pa	Flowrate m ³ /s
Theatre	Existing Theatre Suite to be measured on site	20	25	0.75*
Anaesthetic		15	>10	0.15
Sterile Prep		10	25	0.1
Scrub		-	25	Included within theatre
Disposal		-	0	0.1

*Primary fresh air-flow volume only

The disposal layout detailed will remain the same should a hatch be utilised instead of a door onto the outer corridor. Alternatively the disposal room could be omitted and replaced with a disposal hatch between the theatre and corridor.

Appendix 4: Design of air-movement control schemes for operating theatres.

General

- A4.1 Standard operating suite design solutions are given in [Appendix 3](#). If these standard solutions cannot be used, the following procedure should be adopted, which will result in an acceptable design. Note that the method employed can equally be used to provide a design solution to a ventilated suite of rooms for any application.
- A4.2 The method is concerned with the calculation of airflow rates to ensure that correct air movement occurs between rooms when any one door is open. Under most circumstances, the air quantities required for air-movement control will approximate to those for either temperature control or bacterial contaminant dilution. This flow rate is sufficient to control the effects of any slight reverse flows occurring when a door is opened.
- A4.3 The progression through the design procedure is shown in the airflow design procedure chart ([Figure A4/3](#)) and is supported by worksheets WS1 to WS7 described in [Paragraph A4.4](#). It is recommended that a plan of the suite and an airflow network be made ([Figure A4/2](#)) to collate all information. Flow rates, air-transfer devices etc should be entered as required. The remainder of this Appendix may be treated as reference data to assist in the various steps. The following symbols are used:

S_S – supply airflow rate for summer temperature control;

S_W – supply airflow rate for winter temperature control;

S_D – supply airflow rate for dilution of bacterial contaminants;

S_L – supply airflow rate for heat loss;

S_G – supply airflow rate for heat gain;

E_D – extract airflow rate for dilution of bacterial contaminants;

S_F – final supply airflow rates;

E_F – final extract flow rates;

S_{AMC} – air-supply flow rate for air-movement control;

E_{AMC} – air-extract flow for air-movement control;

L_{OUT} – leakage airflow rate outward;

L_{IN} – leakage airflow rate inward;

Σ_{OUT} – total airflow rate outward;

Σ_{IN} – total airflow rate inward.

A4.4 To simplify the procedure, standard worksheets (WS1 to WS7) have been devised. For each operating suite, a set is required comprising one each of WS1, WS3, WS5, WS6a, WS6b and WS7, one WS4 for each corridor and one WS2 to cover each peripheral room. WS2 has five versions:

- WS2a single flow;
- WS2b parallel/series multi-flow;
- WS2c parallel multi-flow or series multi-flow (unbalanced);
- WS2d series multi-flow (balanced); and
- WS2e bay (semi-open).

Peripheral room type

A4.5 The rooms in the operating suite other than the operating room and corridor are referred to as peripheral rooms. Peripheral rooms have been classified according to the flows in and out. These room classifications are defined below in [Paragraphs A4.6 – A4.11](#).

Single flow

A4.6 This is a room with only one door and a net surplus of supply or extract air.

Parallel multi-flow

A4.7 This is a room with two or more doors through each of which the air-flows either outwards (high-pressure) or inwards (low-pressure) (for example the Prep (lay-up) in [standard layout 5](#)).

Parallel/series multi-flow

A4.8 This is a room having a net surplus of supply or extract and with two or more doors. One or more doors will be to an area of equal cleanliness and need not be protected; hence, the flow may vary between inwards and outwards, the remaining door being to an area of greater or lesser cleanliness (for example the Prep (SPS) in [standard layout 6](#)).

Series multi-flow (unbalanced)

A4.9 This is a room having a net surplus of supply or extract and with two or more doors. Air flows inwards through one or more doors and outwards through one or more doors.

Series multi-flow (balanced)

A4.10 This is a room as in [Paragraph A4.9](#) above, but having either no mechanical ventilation or no net surplus of supply or extract. (for example an anaesthetic room).

Bay

A4.11 A room that has a permanent opening to the operating room may be considered as a bay off the latter (for example a scrub). Two categories exist:

- open bay – the opening is larger than a normal single door opening. The bay may be considered as part of the main room;
- semi-open bay – the opening is no larger than a normal single door opening. In this case it is possible to protect the bay from the main room by provision of air supply or extract in the bay, or by passing air to or from another area.

Air-movement control in peripheral rooms

A4.12 For the design of air-movement control, two types of air-transfer device are considered. These are transfer grilles and pressure stabilisers. Each has a particular field of application within the design, as described in [Paragraphs A4.34 – A4.43](#). Air movement is controlled in each of the different room types described in [Paragraphs A4.13 – A4.31](#).

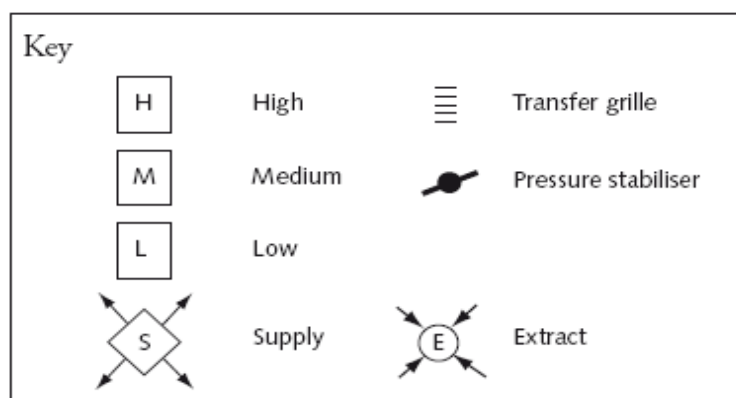

Note: This key applies to each diagram in A4.13 - A4.27.

Single flow rooms

A4.13 An appropriately sized transfer grille should be located in or adjacent to the door of each single flow room to relieve the pressure differences across the door when closed.

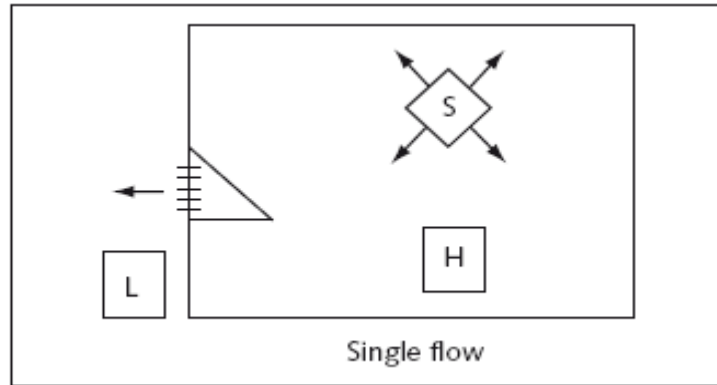

Parallel multi-flow rooms

- A4.14 The pressure difference across the closed doors must be relieved, but transfer grilles are not appropriate where two doors lead to areas of different pressures, because reverse flow could occur when the other door is open. For this reason, pressure stabilisers are used.

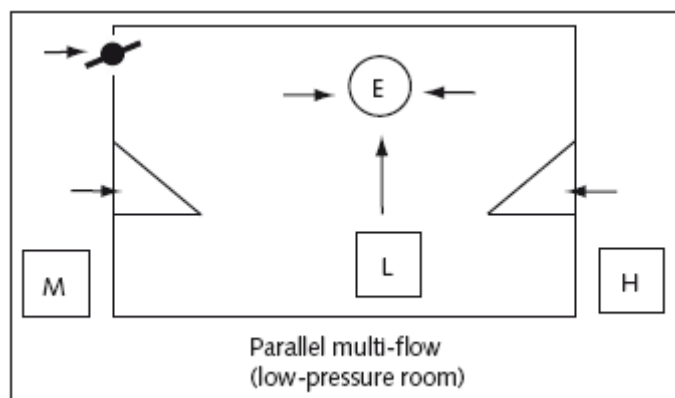
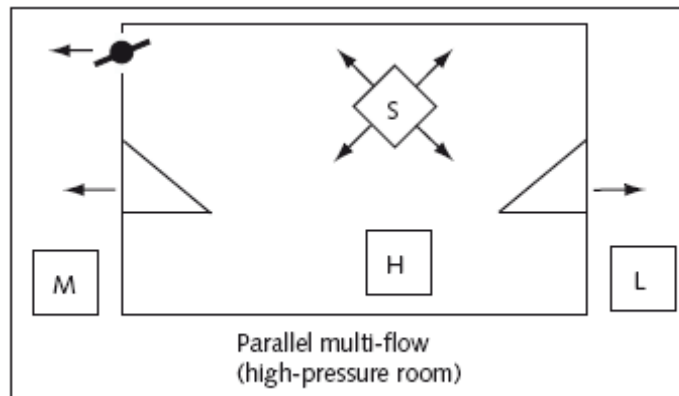

- A4.15 These rooms will be either high-pressure or low-pressure with respect to the adjacent areas (see preparation lay-up room and disposal room, respectively, in [standard layout 5](#)). The pressure-relief damper is always situated between the room and area, which results in the smaller differential pressure to ensure best use of air.
- A4.16 Just as reverse flow can occur if transfer grilles are used, it can similarly occur via door gaps when the other door is opened. It is not possible to avoid this,

except by using air locks, but due to the low flow rates and short durations involved, this is not considered to be of importance.

Parallel-series multi-flow rooms

- A4.17 These rooms are similar to those in Paragraph A4.14 above, but because the room is of equal cleanliness to one of the adjacent rooms the nominal pressures will be equal and air may flow through the adjoining doorway in either direction. (for example the Prep (SPS) in [standard layout 6](#)).

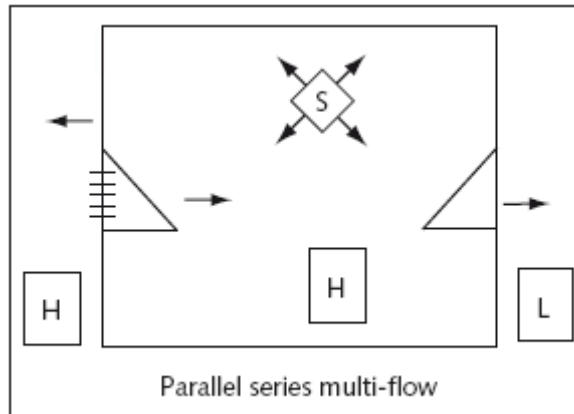

- A4.18 Where the nominal room pressure equals that of the higher-pressure adjacent room, the best use of air is by supplying air required for bacterial dilution only and allowing this to exhaust via a transfer grille to the area of equal cleanliness. The doorway to the lower pressure area is protected by the combination of the supply air and the air that will flow inwards through the transfer grille from the area of equal cleanliness.

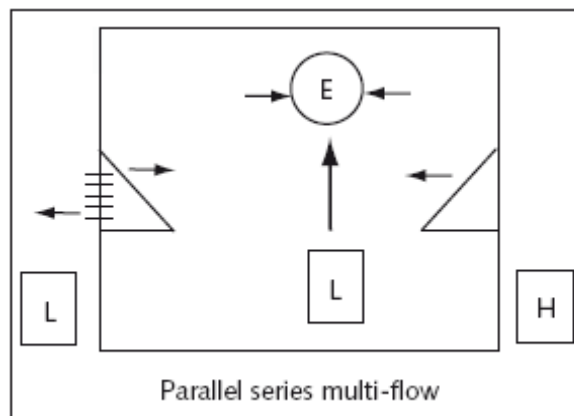

- A4.19 Conversely, where the nominal pressure equals that of the lower-pressure adjacent room, extract ventilation and a transfer grille to the lower pressure adjacent room should be provided. (for example, the disposal room in [standard layout 8](#)).

Series multi-flow (unbalanced)

- A4.20 These rooms are somewhat similar to those in Paragraph A4.15 above, but because the pressure lies between that of the rooms on either side, the back-flow problem does not exist.

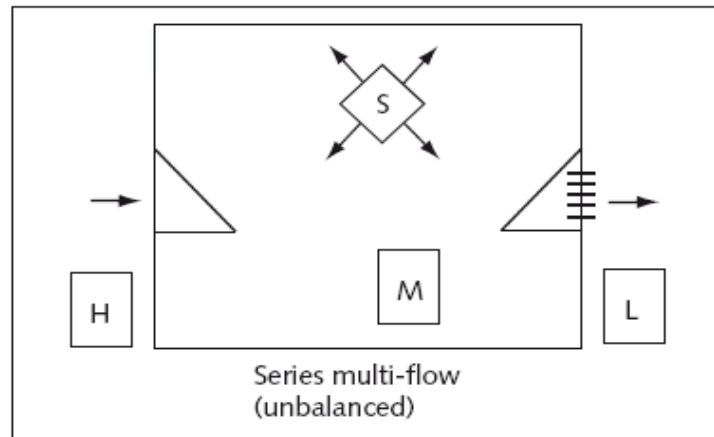

- A4.21 Where the room has a net surplus of mechanical supply air, a transfer grille should be located in or adjacent to the door through which air flows outwards, and the mechanical supply flow rate to the room should be chosen to give protection when this door is open.
- A4.22 Where the room has a net surplus of mechanical extract air, a transfer grille should be located adjacent to the door through which the air flows inwards, and the mechanical extract flow rate to the room should be chosen to give protection when this door is open.
- A4.23 The grille must be sized for the protection requirement of the opposing door when open. When the room on the high-pressure side depressurises, there is a possibility of back-flow through gaps around the door, but this problem may be ignored.

Series multi-flow (balanced)

- A4.24 In these rooms, a transfer device adjacent to each doorway is required in order to provide a flow path for the air required to protect the opposing door when opened.

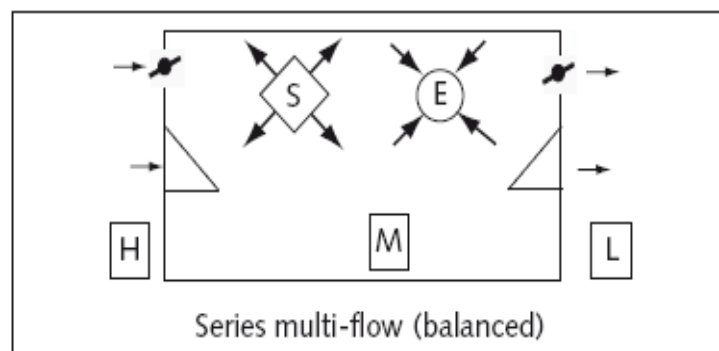

- A4.25 These transfer devices will normally be pressure stabilisers, although transfer grilles may be used where a large amount of excess air is to be exhausted from the operating room when all doors are closed. (for example, anaesthetic rooms).
- A4.26 The calculation procedure is to assume that pressure stabilisers are being used; then (if there is sufficient excess air) change to transfer grilles as described in Paragraph A4.50.

Bay

Open bay

- A4.27 A bay of the open type (for example scrub-up) is considered to be part of the operating room. Provided air movement is satisfactory, no specific extract is required.

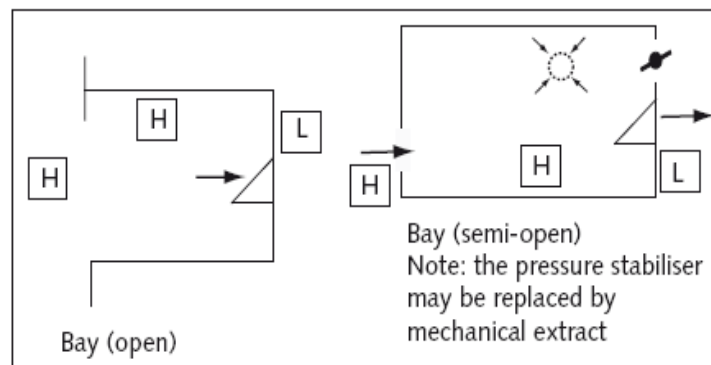

Semi-open bay

- A4.28 In a bay of the semi-open type, protection of one area from the other is possible. (For example scrub-up).
- A4.29 As stated previously, the need for protection between operating room and scrub-room is not very great. Better use of air can therefore be achieved in this case by installing a pressure stabiliser between the scrub-room and clean corridor. This will allow a flow of air through the scrub-room at all times, except when a door is opened elsewhere in the suite. The pressure stabiliser will then close and the air will be diverted to the other door. When it is considered necessary to protect the scrub-room at all times, either a transfer grille to the corridor or mechanical extract in the scrub-room should be provided.

Operating room

- A4.30 Once the peripheral rooms have been considered, the operating room requirements may then be decided and the supply flow rate required for air-movement control calculated. This flow rate should be such that, with any one door open, the correct air movement directions are maintained. There will be one door in the suite that will require the largest supply flow rate to the

operating room for protection when open. This is called the “key door” and is discussed separately in [Paragraph A4.33](#). Use of this concept avoids repetitive calculations for each door in turn. Having established the required supply flow rate, a relief route must be provided to the clean corridor for any excess air when the doors are closed. This would be via transfer grilles or pressure stabilisers through a series-flow room or via pressure stabilisers to the clean corridor directly.

Corridors

- A4.31 All surplus air from the suite, except that lost through structure leakage and any passing to the outer corridor, will arrive in the patient/staff corridor. Should this air be insufficient to achieve the required air-change rate (see [Appendices 1 and 2](#)), some additional air supply should be provided. (The air balance should take account of structural leakage.)

Door opening

- A4.32 Whereas the resulting pressures are dependent on ductwork layout, room relationships and characteristics of the fan, the generalisations shown in [Appendix 2](#) can be used to estimate the change in room pressure when a door is opened.
- A4.33 The “key door” will be the open double door which leaves the operating room at the highest pressure, and/or requires the largest air flow. This should be determined using the procedure in worksheet WS3.

Transfer grilles

- A4.34 These may be used to limit the pressure differences across the closed door of a single-flow room or, in some instances, for protection of a series-flow or parallel-series-flow room. They allow airflow in both directions and may not be suitable for all applications.
- A4.35 The free area of a grille is calculated from the following equation:

$$A = \frac{Q}{0.84\sqrt{\Delta P}}$$

where:

A is free area (m²)

Q is flow rate (m³/s)

P is pressure difference (Pa).

- A4.36 The flow through a grille at a different pressure may be found from the following equation:

$$Q_2 = Q_1 \sqrt{\frac{\Delta P_1}{\Delta P_2}}$$

where:

Q_1 and P_1 are original flow and differential pressure

Q_2 and P_2 are new flow and differential pressure.

- A4.37 The transfer grille may be replaced by carefully proportioned door undercuts of the equivalent free area.
- A4.38 The function of the transfer grille is to provide a means of airflow control by which the volume and pressure loss can be established. If a grille is used, it should have an easily removable core to facilitate cleaning.

Pressure-relief dampers

- A4.39 The functions of a pressure-relief damper are now carried out by pressure stabilisers. Accordingly, all further mention of them has been removed from this document.

Pressure stabilisers

- A4.40 Pressure stabilisers can be adjusted to hold the pressure constant over a wide range of flow rates. They are used where requirements exist for accurate room-pressure control or rapid shut-off on pressure fall.
- A4.41 The installation of a grille or baffle in association with a stabiliser will alter the operating characteristics. It is recommended that a location be chosen to avoid the need for visual screening, for example, at high level. The location should be chosen to minimise the likelihood of damage.
- A4.42 The stabilisers used should be virtually silent in operation, adjustable on site, maintenance-free and of a type that cannot be wrongly inserted. They should not be used in external walls or where the pressure difference is less than 5 Pa. The required size of a pressure stabiliser is dependent on the design pressure difference across it and flow rate through it. The manufacturer should provide data relating pressure difference to mean velocity (or flow rate per unit area). From this, the required area can be calculated and then rounded-up to the nearest size manufactured or nearest combination of smaller sizes.
- A4.43 It is sometimes possible to arrange for a pressure stabiliser to perform two tasks. In an anaesthetic room, for example, the two pressure stabilisers may be made to pass the open door protection air, and also control the operating and anaesthetic room pressures with the door closed. To achieve this, the

stabilisers are sized for the flow rate required with one of the doors open, but the pressure setting is adjusted to be the value required with the doors closed. This is shown in [Figure A4/1](#).

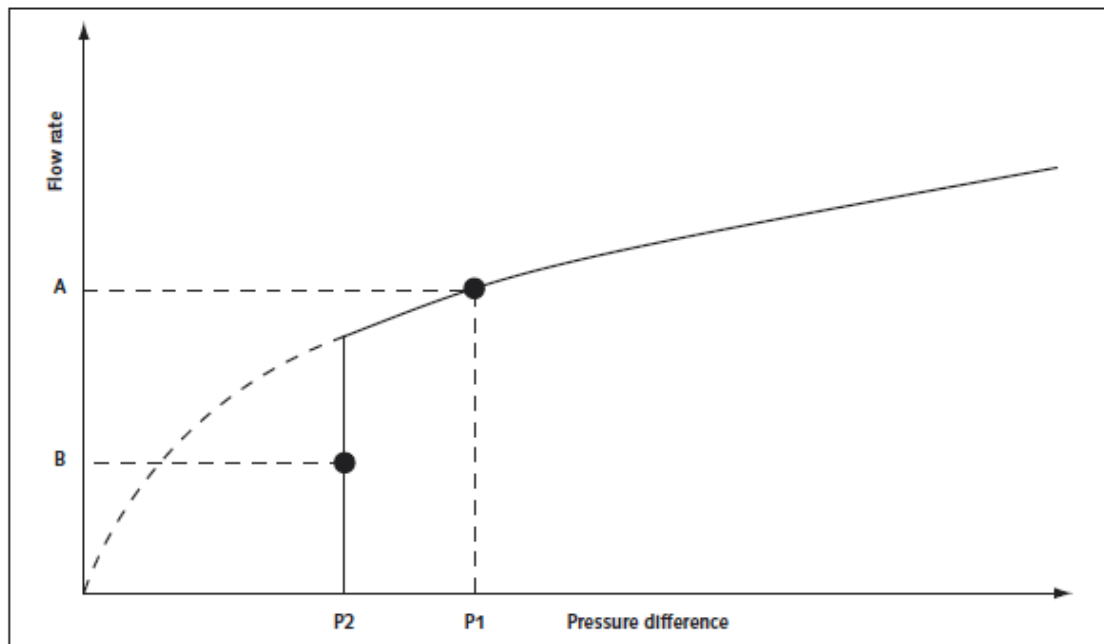

Figure A4/1

Door leakage flows

- A4.44 For an air-movement control scheme to work satisfactorily, it is essential that the estimates of door-gap leakage made at the design stage are closely related to those which are achieved in practice. The calculation of gap-flows is complicated by the fact that such flows generally fall into the transition region between laminar and turbulent flow and hence do not follow the normal flow equations. The gaps assumed are 4mm along the bottom, 3mm at the top and sides, and 2mm between double leaves. Doors should not have wider gaps than these. Tighter gaps would result in lower flow-rate requirements and hence lower fan power, but care should be taken to ensure that all doors in the suite have similar gap dimensions. It may be possible to ignore the door leakage and so reduce the airflow requirement (see the notes in [Appendix 3](#)).

Room temperature estimation

- A4.45 The air-flow rate required to prevent back-flow through an open door is dependent on the temperature difference across the door. The design figures shown in [Appendix 3](#) are based on the temperature differences that will normally occur in practice, assuming heat gains and losses in accordance with [Appendix 2](#).
- A4.46 In accordance with the airflow design process, the temperature differences across the doors of all rooms classed as “sterile” is calculated. Worksheet WS6 is recommended for the calculations, using the following criteria:

- assume that the operating room is being controlled at 20°C and calculate the incoming air-supply temperature as shown on worksheet WS6;
- the calculation should be repeated for both summer and winter conditions, with an operation in progress;
- assume all doors are closed;
- use the room supply flow rates from WS1;
- use the inward air flows through air-transfer devices and closed door leakages from WS2a to WS2e;
- the formula used in worksheet WS6 is as follows:

$$T = \frac{(t_1 Q_1 + t_2 Q_2 + \dots + t_n Q_n) + 0.828H}{(Q_1 + Q_2 + \dots + Q_n)}$$

where:

Q = flow rate from source (m³/s)

t = the temperature of source (°C)

H = the room heat gain (kW).

A4.47 If the evaluated temperature differences between rooms do not exceed 2°C, the solution is satisfactory; otherwise proceed as follows:

- check the assumption on which the heat gains are based;
- take steps to reduce the heat gains;
- if the door is to a corridor, the flow through the open door will be larger than the value given in [Appendix 2](#). Calculate on WS3, assuming it is the “key door” with door-flow unknown, and the supply as known;
- if the door leads to a room with mechanical supply, install a trimmer heater in the supply to the room controlled by either a differential thermostat or a thermostat slaved to the operating room thermostat to ensure that T is minimized.
- If the door leads to a room with no mechanical supply, increase the door protection flow as follows:

$$Q_{\text{new}} = Q_{\text{old}} \left[\frac{\Delta T + 1}{2} \right]$$

A4.48 These options should be considered in the above order, and the first three should be investigated thoroughly before proceeding to the latter two. The mechanical supply may need to be increased in order to achieve the desired air-change rates.

Relief of excess air from operating room when all doors are closed

- A4.49 As the mechanical supply to the operating room is sized to provide an appropriate flow outward through any door that is opened, it follows that when all doors are closed, there will be more air supplied to the operating room than can exit from it via leaks etc. This “excess” air can be relieved by either of the two methods described in [Paragraphs A4.50 - 4.54](#).

By transfer devices via the anaesthetic room

- A4.50 For door protection, the transfer devices in the anaesthetic room are typically designed to pass 0.47 m³/s at a differential pressure of 14 Pa. When the doors are closed, the differential pressure will change to 11 Pa between theatre and anaesthetic room, and 14 Pa between anaesthetic room and corridor; the volume of air passed by the transfer devices will be modified as shown in the following formula:

$$\begin{aligned} Q &= Q_1 \left(\frac{\Delta P_1}{\Delta P_2} \right)^{1/2} \\ &= 0.47 \left(\frac{11}{14} \right)^{1/2} \\ &= 0.42 \text{ m}^3/\text{s} \end{aligned}$$

where:

Q = “excess” air to be vented with doors closed;

Q₁ = air-flow required for door protection through transfer device;

ΔP₁ = nominal differential pressure with door to operating room closed and door to corridor closed;

ΔP₂ = nominal differential pressure between either the anaesthetic room and corridor when the operating room door is open, or the anaesthetic room and operating room when the corridor is open. This differential pressure is used when selecting size of both devices.

- A4.51 If the “excess” air is less than 0.42 m³/s, a pressure stabiliser is required to ensure that the correct protection airflow is available to pass through the door.
- A4.52 If the “excess” air is greater than 0.42 m³/s, a transfer grille is acceptable because at all times the airflow will exceed the flow required for door protection.

By pressure stabilisers to the corridor

- A4.53 If it is undesirable to pass operating room air through the anaesthetic room, it may be passed directly to a corridor via a separate pressure stabiliser.

A4.54 If there is sufficient “excess” air, the transfer grille solution at Paragraph A4.52 should be adopted, as it provides the simplest solution and, once set up, will require no further maintenance. With less excess air, it is recommended that the air be passed through the anaesthetic room via the pressure stabilisers as at Paragraph A4.51, thus keeping the number of pressure stabilisers to a minimum. Both these solutions increase the air-change rate in the anaesthetic room, but care should be taken to avoid passing excessive amounts through that would cause discomfort to the occupants.

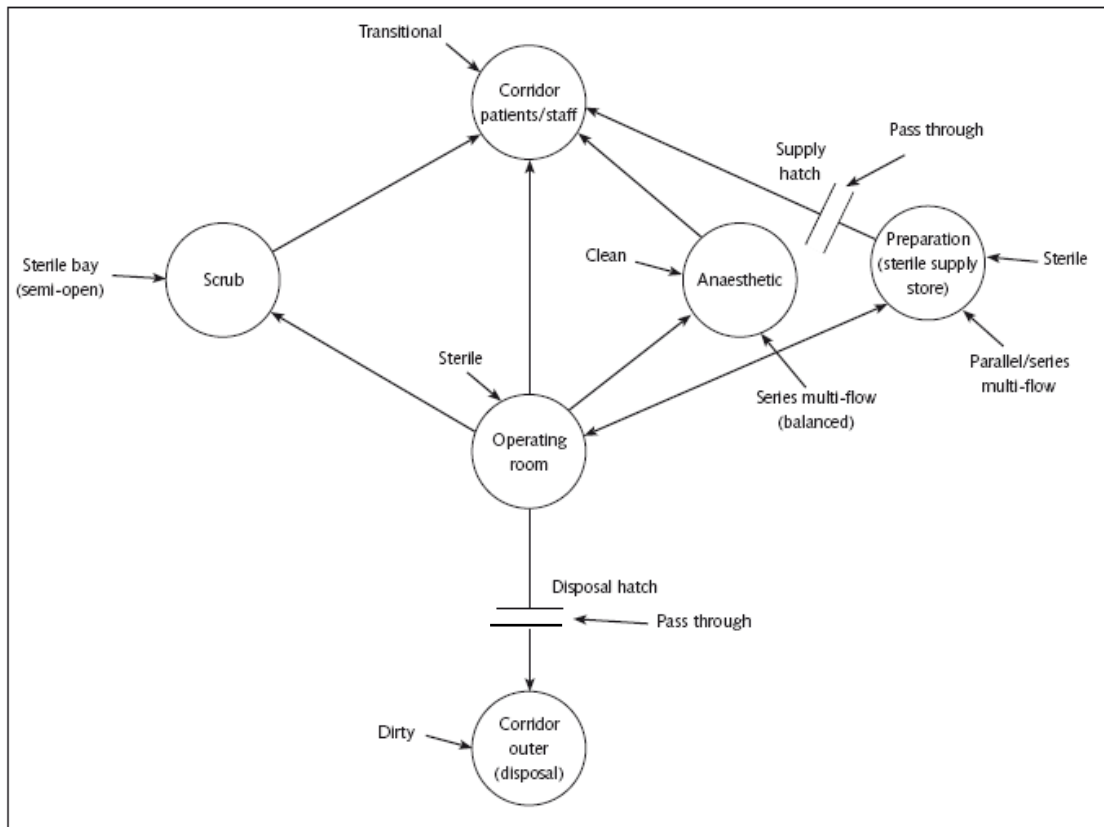
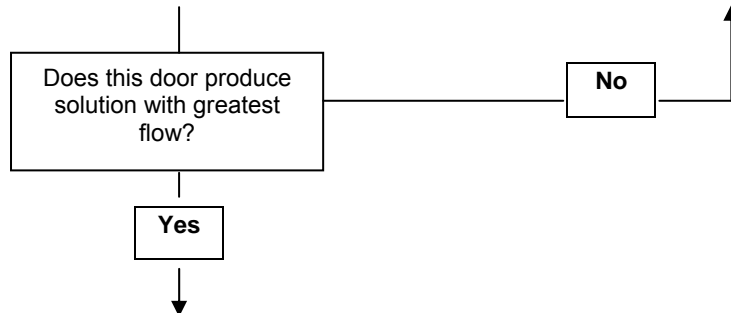
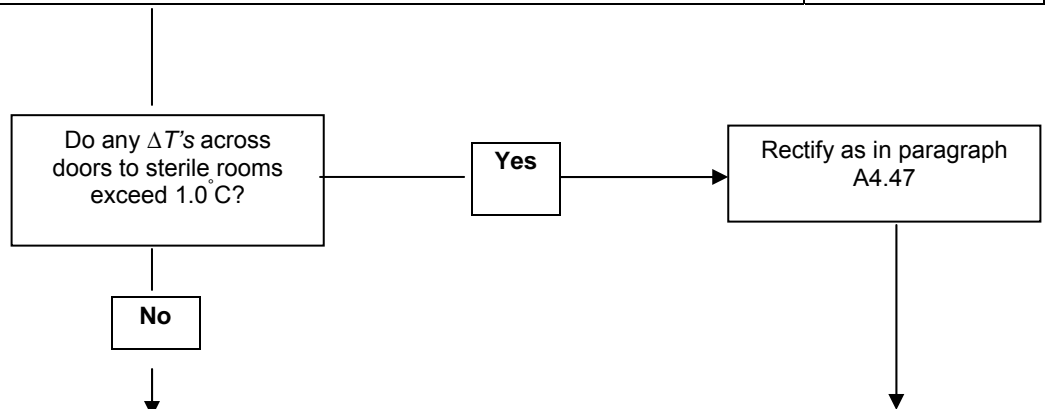

Figure A4/2: An example of an airflow network

Step	Description	Worksheet
1	Show nominal room pressures and air flow directions on the plan of the theatre suite and WS1	WS1
2	Enter heat/loss/gain data and calculate supply airflow rates for temperature control only. Categorise room types e.g. sterile, clean etc.	WS1
3	Enter airflows required for bacterial contamination control or air change rate whichever is the greater, add supply and extract volumes (S_D , E_D) on the plan.	WS1
4	Define peripheral room types, see paragraphs A4.5 - A4.11, and select appropriate worksheets.	Select from WS2a - WS2e
5	Locate air transfer devices, enter details on worksheets and locate on the plan and Figure A4/2	Selected worksheets from WS2a - WS2e
6	For each peripheral room, determine air flows through doors when open and calculate mechanical supply or extract and transfer device flows	As above
7	Select "Key Door" and calculate air supply for operating room	WS3



8	Transfer to WS1 and select final rate S_F and E_F	WS1, WS3
9	Make provision for relief of excess air with doors closed	Selected Worksheets and WS3
10	Calculate supply and extract flow rates for corridor(s)	WS4, WS5
11	Calculate room temperatures (all doors closed) and ΔT 's	WS4, WS5



12	Make summary of flows	WS6a and WS6b
13	Size transfer devices, size ductwork, central plant etc	WS7
14	Design ductwork layout, control plant etc	

Figure A4/3: Airflow design procedures

Calculation sheet for		Worksheet WS1				
		Reference:				
Room Name:						
1. Summer Temperature Control						
Heat Gain	kW					
2. Acceptable Δt	$^{\circ}\text{C}$					
3. Air flow rate (S_G)						
$= \frac{\text{Gain}}{\Delta t \times 1.2}$	m^3/s					
4. Winter Temperature Control						
Heat Loss	kW					
5. Acceptable Δt	$^{\circ}\text{C}$					
6. Air flow rate (S_L)						
$= \frac{\text{Loss}}{\Delta t \times 1.2}$	m^3/s					
7. Dilution of bacterial contaminations						
Air flow rate	m^3/s					
S_D or E_D						
8. Desired air change rate	ac/hr					
$\frac{\text{AC/hr} \times \text{room volume (m}^3\text{)}}{3600}$	m^3/s					
9. Maximum of S_G , S_L , S_D or E_D or air change rate from Step 8	m^3/s					
10. Air movement control	S m^3/s					
Air flow for air movement control S_{AMC} or E_{AMC} (from WS2, WS3, or WS4)	E m^3/s					
11. Final Supply Flow Rate (S_F)	m^3/s					
12. Final Extract	m^3/s					
13. Total Supply		m^3/s				
14. Total Extract		m^3/s				

Surveyor (AP(V)/CP(V))..... Date.....

Air Movement Control	Worksheet WS2a				
Peripheral Room type, single flow	Reference:				
	Nominal Pressure: Pa				
Consider door to open					
	Air flow, m ³ /s				
Flow required through doorway to give protection	Pa	Δt	Out	In	Remarks
	Total				
$S_{AMC} (\sum OUT - \sum IN)$ <input type="text"/> m ³ /s or $E_{AMC} (\sum OUT - \sum IN)$ <input type="text"/> m ³ /s Transfer S_{AMC} or E_{AMC} to WS1					
Consider door toclosed					
	Pa	Δt	Out	In	Remarks
Closed door leakage					
	Total				
Return S_F and E_F to WS1 <input type="text"/> <input type="text"/> Flow through transfer grille outward ($S_F - E_F - L_{OUT}$) <input type="text"/> or Flow through transfer grille inward ($E_F - S_F - L_{IN}$) <input type="text"/>					

Surveyor (AP(V)/CP(V))..... Date.....

Air movement control		Worksheet WS2b			
Peripheral Room type, parallel/series multi-flow		References:			
		Nominal Pa		Pressure:	
Door from this room to (room of equal cleanliness) is not to be protected. A transfer grille is located in, or adjacent to, this door.					
Consider door to open					
Room pressure now becomes <input type="text"/> or <input type="text"/> or <input type="text"/> Pa (see Appendix 6)					
		Air flow, m ³ /s			
		Out	In	Remarks	
Flow required through doorway to give protection					
At above pressures leaks through closed doors	Pa	ΔP			
Mechanical supply or extract (S _F /E _F)					
Total					
X ($\sum_{OUT} - \sum_{IN}$) <input type="text"/> Or Y ($\sum_{IN} - \sum_{OUT}$) <input type="text"/>					
Transfer grille required:					
or from high-pressure zone Flow = X <input type="text"/> at <input type="text"/> ΔPa					
to low-pressure zone Flow = Y <input type="text"/>					
Size of transfer grille (free area) A1 <input type="text"/>					
Consider doors and hatch closed – room pressure becomes <input type="text"/> Pa (nominal)					
Closed door leakage from Appendix 4 (assuming no transfer grille)	Pa	ΔP	Out	In	Remarks
Mechanical supply or extract					
Total					
Air flow required through transfer grille = IN – OUT = Z' <input type="text"/>					
= Z'' or OUT – IN <input type="text"/>					
Transfer grille required flow Z' or Z'' <input type="text"/> @ <input type="text"/> ΔP					
Size of transfer grille (free area) A2 = <input type="text"/>					
Select larger of A1 or A2 <input type="text"/>					

Surveyor (AP(V)/CP(V))..... Date.....

Air movement control			Worksheet WS2c			
Peripheral Room type, parallel multi-flow high/low or series multi-flow (unbalanced)			References:			
			Nominal Pressure: Pa			
Consider door from this room to open.						
Room pressure now becomes <input style="width: 50px;" type="text"/> or <input style="width: 50px;" type="text"/> or <input style="width: 50px;" type="text"/> Pa (see Appendix 6)						
			Air flow, m ³ /s			
			Out	In	Remarks	
Flow required through doorway to give protection						
At above pressures leaks through closed doors		Pa	ΔP			
Total						
$S_1 (\sum_{OUT} - \sum_{IN})$ <input style="width: 50px;" type="text"/> Or $E_1 (\sum_{IN} - \sum_{OUT})$ <input style="width: 50px;" type="text"/>						
Consider door from this room to open						
Room pressure then becomes <input style="width: 50px;" type="text"/> or <input style="width: 50px;" type="text"/> or <input style="width: 50px;" type="text"/> Pa						
			Out	In	Remarks	
Flow required through open doorway to give protection						
At above pressures leaks through closed doors are:		Pa	ΔP			
Total						
$S_2 (\sum_{OUT} - \sum_{IN})$ <input style="width: 50px;" type="text"/> Or $E_2 (\sum_{IN} - \sum_{OUT})$ <input style="width: 50px;" type="text"/>						
Consider doors closed. Closed doors leakage from Appendix 4						
Door to:		Pa	ΔP	Out	In	Remarks
Total						
Return S_F and E_F to WS1 <input style="width: 50px;" type="text"/> <input style="width: 50px;" type="text"/>						
Flow through transfer grille outward ($S_F - L_{OUT}$) <input style="width: 50px;" type="text"/> to						
or						
Flow through transfer grille inward ($E_F - L_{IN}$) <input style="width: 50px;" type="text"/> from.....						
Transfer grille <input style="width: 50px;" type="text"/>		Pressure relief damper <input style="width: 50px;" type="text"/>				

Surveyor (AP(V)/CP(V))..... Date.....

Air movement control			Worksheet WS2d		
Peripheral Room type, parallel/series multi-flow			References:		
			Nominal Pressure: Pa		
Note: In this type of room the supply and extract air flow rates are equal and take no part in the air movement control (AMC)					
First, open door to higher pressure area.					
Room pressure then becomes <input style="width: 50px;" type="text"/> or <input style="width: 50px;" type="text"/> or <input style="width: 50px;" type="text"/> Pa (see Appendix 2)					
			Air flow, m ³ /s		
			Out	In	Remarks
Flow required through doorway to give protection					
At above pressures leaks through closed doors	Pa	ΔP			
Total					
$Q_1 (\sum_{IN} - \sum_{OUT})$ <input style="width: 50px;" type="text"/> (+ve inwards)					
Next, open door to lower pressure area.					
Room pressure then becomes <input style="width: 50px;" type="text"/> or <input style="width: 50px;" type="text"/> or <input style="width: 50px;" type="text"/> Pa					
			Out	In	Remarks
Flow required through open doorway to give protection					
At above pressures leaks through closed doors are:	Pa	ΔP			
Total					
$Q_1 (\sum_{IN} - \sum_{OUT})$ <input style="width: 50px;" type="text"/> (+ve inwards)					
Flow through transfer device (TD1) to protect Door 1 = Q1 <input style="width: 50px;" type="text"/>					
ΔP					
Flow through transfer device (TD2) to protect Door 2 = Q2 <input style="width: 50px;" type="text"/>					
ΔP					

Surveyor (AP(V)/CP(V))..... Date.....

Air movement control			Worksheet WS2e		
Peripheral Room type bay (semi-open)			References:		
			Nominal Pressure: Pa		
<p>Note: If the room is of the open bay type (i.e. opening is larger than normal single doorway), then room should be considered part of the main room. No air movement control considerations need then be made, and this sheet can be discarded. Supply and/or extract flow will be based on air distribution considerations.</p> <p>Consider permanent opening</p>					
Flow required through doorway to give protection			Air flow, m ³ /s		
			Out	In	Remarks
At above pressures leaks through closed doors	Pa	ΔP			
Total					
E_{AMC} <input style="width: 100px;" type="text"/> or flow outward through transfer ($\sum IN - \sum OUT$) <input style="width: 100px;" type="text"/>					
Transfer S_{AMC} or E_{AMC} to WS1					
Transfer device – transfer grille <input style="width: 100px;" type="text"/>					
– pressure stabiliser <input style="width: 100px;" type="text"/>					
Size select transfer device for flow rate <input style="width: 100px;" type="text"/> @ ΔP <input style="width: 100px;" type="text"/>					
Note: A door from the bay is considered with the peripheral room to which it leads or, if it leads to the corridor, it is considered with the main room.					

Surveyor (AP(V)/CP(V))..... Date.....

Air movement control			Worksheet WS3		
Operating Room			References:		
			Nominal Pressure: Pa		
<p>Note: To avoid considering each door open in turn, the “key door” concept is introduced. This is the door which requires the greatest mechanical flow when open. See paragraph A4.33</p>					
<p>Select “key door” (see above). Consider this door open – room pressure now becomes <input style="width: 100px;" type="text"/> Pa (See Appendix 2) See Appendix 3 for room pressures</p>					
			Air flow, m ³ /s		
			Out	In	Remarks
Flow required through doorway to give protection					
Air flow “out” or “in” via doors, transfer devices etc.	Pa	ΔP			
Mechanical extract					
Total					
<p>S_{AMC} ($\sum_{OUT} - \sum_{IN}$) <input style="width: 100px;" type="text"/> Transfer S_{AMC} to WS1 Consider all doors closed. Return S_F and E_F to WS1 <input style="width: 100px;" type="text"/> Room pressure now <input style="width: 100px;" type="text"/> Pa (nominal)</p>					
Air flow “out” or “in” via door leakage, transfer devices etc	Pa	Δt	Out	In	Remarks
Mechanical extract					
Total					
<p>Flow ($\sum_{IN} - \sum_{OUT}$) through transfer device <input style="width: 100px;" type="text"/> @ ΔP <input style="width: 100px;" type="text"/> to..... </p>					
For final selection of transfer device see paragraphs A4.50 – A4.54					

Surveyor (AP(V)/CP(V))..... Date.....

Air movement control	Worksheet WS4		
Corridor	References:		
	Nominal Pressure:		Pa
Consider all doors closed			
		Air flow, m ³ /s	
		Out	In
		Remarks	
Flow required through doorway to give protection			
Leaks through closed doors, transfer devices, permanent openings etc.	Pa	ΔP	
Total flow inwards (S ₁)			
Add mechanical input (S ₂) if necessary to increase S ₁ to give 7 AC/hr			
Total Flow Outwards and Inwards			
$S_{AMC} = (\sum OUT - \sum IN + S_2)$		<input style="width: 100px; height: 20px;" type="text"/>	Transfer to WS5
<i>or</i> $E_{AMC} = (\sum IN - \sum OUT + S_2)$		<input style="width: 100px; height: 20px;" type="text"/>	Transfer to WS5

Surveyor (AP(V)/CP(V))..... Date.....

Air movement control		Worksheet WS5	
Corridor		References:	
Summary of Air Supply and extract for an Operating Suite			
Consider all doors closed			
Air Flow to Corridor	All Doors Closed	Anaesthetic (key door open)	
	m ³ /s	m ³ /s	
From Preparation			
From Operating Room			
From Scrub			
From Anaesthetic			
Total (a)			
Air Flow to Corridor from Disposal			
From other source			
Total (b)			
Other Room Supplies.....Total (c)			
Total Air Supply (a) + (b) + (c)			
Consider corridor ventilation (see Appendix 2) and calculate air volume required, based on 7 ac/hr (see Note 1)			
		m ³ /s	
Additional Air to Ventilate Corridor			
Additional Air to Ventilate Service Corridor (see Note 2)			
Air Extract			
The size of the extract plant should be of the order of 10% below the supply to assist in maintaining the department under positive pressure relative to the outside departments.			
		m ³ /s	
Extract Plant = Supply less Leakage			
Less 10% of Supply			
Total Extract (see Note 3)			

Surveyor (AP(V)/CP(V))..... Date.....

Room Temperature - Summer		Worksheet WS6a																	
		References:																	
Find summer supply temperature $T_{SS} = 20 - 0.828 \frac{H(O/R)}{Q(O/R)}$				°C															
		$= T_{SS}$																	
<p>Note: The temperature of a space may be calculated from</p> $T = \frac{t_1 Q_1 + t_2 Q_2 + \dots + t_n Q_n + (0.828H)}{Q_1 + Q_2 + \dots + Q_n}$ <p>Where t_1 is temperature of source (1°C) Q_1 is flow from source 1 when all doors are closed (m³/s) H is heat gain in space (kW)</p>																			
Summary of Air Supply and extract for an Operating Suite																			
Consider all doors closed																			
Room	Heat Gain kWh	Supply		Flows Inwards										Tem- pera- ture °C T					
		Q	T_{SS}	From		From		From		From		From							
				Q	t	Q	t	Q	t	Q	t	Q	t						
Check Doors to Sterile Areas																			
Door Between		Calculated Room ΔT (°C)				Maximum ΔT Permitted				Remarks									

Surveyor (AP(V)/CP(V))..... Date.....

Room Temperature - Winter	Worksheet WS6b
	References:

Find winter supply temperature $T_{SW} = 20 - 0.828 \frac{H(O/R)}{Q(O/R)}$

= T_{SW} °C

Note: The temperature of a space may be calculated from

$$T = \frac{t_1 Q_1 + t_2 Q_2 + \dots + t_n Q_n + (0.828H)}{Q_1 + Q_2 + \dots + Q_n}$$

Where t_1 is temperature of source (1°C)
 Q_1 is flow from source 1 when all doors are closed (m³/s)
 H is heat gain in space (kW)

Summary of Air Supply and extract for an Operating Suite

Consider all doors closed

Room	Heat Gain kWh	Supply		Flows Inwards										Temperature °C T			
		Q	T _{SW}	From		From		From		From		From					
				Q	t	Q	t	Q	t	Q	t	Q	t				

Check Doors to Sterile Areas

Door Between	Calculated Room ΔT (°C)	Maximum ΔT Permitted	Remarks

Surveyor (AP(V)/CP(V))..... Date.....

Transfer Grilles, Pressure Relief Dampers and Pressure Stabilisers	Worksheet WS7 Reference:
---	---

Transfer Grilles – see paragraphs A4.34 – A4.38

Check Doors to Sterile Areas

No	Location	Pressure Difference Pa	Flow Rate m ³ /s	Free Area m ²	Model	Resultant Δp Pa	Remarks

Pressure Relief Dampers – see paragraph A4.39

No	Location	Pressure Difference Pa	Flow Rate m ³ /s	Free Area m ²	Pressure Setting Pa	Remarks

Pressure Stabilisers –see paragraphs A4.40 – A4.43

Note: where a stabiliser is acting both as series room door protection and operating pressure control, “pressure difference” and “flow rate” are from WS2d; “pressure setting” is from WS3

No	Location	Pressure Difference Pa	Flow Rate m ³ /s	Free Area m ²	Pressure Setting Pa	Remarks

Surveyor (AP(V)/CP(V))..... Date.....

References

Acts and regulations

Scottish Technical Handbooks Non Domestic. Scottish Building Standards Agency, 2007. <http://sbsa.gov.uk>

Scottish Technical Handbooks, Non Domestic, Section 2: Fire. Scottish Building Standards Agency. 2007 <http://sbsa.gov.uk>

Scottish Technical Handbooks, Non Domestic Section 6: Energy. Scottish Building Standards Agency 2007. <http://sbsa.gov.uk>

Control of Substances Hazardous to Health Regulations (COSHH) 2002. SI 2002 No 2677. TSO, 2002. www.opsi.gov.uk/si/si2002/20022677.htm

(The) Health & Social Care Act 2008: Code of practice for the prevention and control of healthcare associated infections. 2008. www.dh.gov.uk

Health and Safety at Work etc Act 1974. HMSO, 1974.

Management of Health and Safety at Work Regulations 1999. SI 1999 No 3242. TSO, 1999. www.opsi.gov.uk/SI/si1999/19993242.htm

Medicines Act 1968. TSO, 1968.

Provision and Use of Work Equipment Regulations 1998. SI 1998 No 2306. HMSO, 1998. www.opsi.gov.uk/SI/si1998/19982306.htm

Workplace (Health, Safety and Welfare) Regulations 1992. SI 1992 No 3004. HMSO, 1992. www.opsi.gov.uk/si/si1992/Uksi_19923004_en_1.htm

British Standards

BS5588-9: 1999. Fire precautions in the design, construction and use of buildings. Code of practice for ventilation and air conditioning ductwork. British Standards Institution, 1999.

BS5726: 2005. Microbiological safety cabinets. Information to be supplied by the purchaser to the vendor and to the installer, and siting and use of cabinets. Recommendations and guidance, British Standards Institution, 2005.

BS5925: 1991. Code of practice for ventilation principles and designing for natural ventilation. British Standards Institution, 1991.

BS EN 779: 2002. Particulate air filters for general ventilation. Determination of the filtration performance. British Standards Institution, 2002.

BS EN 1822-1:1998. High efficiency air filters (HEPA and ULPA). Classification, performance testing, marking. British Standards Institution, 1998.

BS EN 1822-2:1998. High efficiency air filters (HEPA and ULPA). Aerosol production, measuring equipment, particle counting statistics. British Standards Institution, 1998.

BS EN 1822-3:1998. High efficiency air filters (HEPA and ULPA). Testing flat sheet filter media.

BS EN 1822-4:2000. High efficiency air filters (HEPA and ULPA). Determining leakage of filter element (scan method).

BS EN 1822-5:2000. High efficiency air filters (HEPA and ULPA). Determining the efficiency of filter element.

BS EN 12469:2000. Biotechnology. Performance criteria for microbiological safety cabinets.

BS EN 13030:2001. Ventilation for buildings. Terminals. Performance testing of louvres subjected to simulated rain.

BS EN 14175-2:2003. Fume cupboards. Safety and performance requirements.

BS EN ISO 14644-1:1999. Clean rooms and associated controlled environments. Classification of air cleanliness.

BS EN ISO 14644-4:2001. Clean rooms and associated controlled environments. Design, construction and start-up.

Department of Health Publications

Health Building Note 26 – Facilities for surgical procedures. The Stationery Office, 2004.

Health Technical Specification C04 – Mechanical ventilation and air conditioning systems. The Stationery Office, 1997.

NHSScotland Publications

Scottish Health Planning Note 13: Sterile services department. Health Facilities Scotland forthcoming.

Scottish Health Technical Memorandum 04-01: The control of *Legionella*, hygiene, 'safe' hot water, cold water and drinking water systems. Health facilities Scotland 2010.

Scottish Health Technical Memorandum 55: Windows. Health Facilities Scotland 2006

Scottish Health Technical Memorandum 58: Internal doorsets. Health Facilities Scotland 2006

Scottish Health Technical Memorandum 81: Fire Preventions in New Hospitals. Health Facilities Scotland 2003.

Scottish Health Technical Memorandum 07-02: Environment and Sustainability. Health Facilities Scotland 2006

Scottish Health Technical Memorandum 08-01: Acoustics. Health Facilities Scotland 2011

Scottish Health Facilities Note 30: Infection Control in The Built Environment: Design and planning. Health Facilities Scotland 2007.

Chartered Institution of Building Services Engineers publications

Applications Manual AM10: Natural ventilation in non-domestic buildings. CIBSE, 2005.

Applications Manual AM13: Mixed mode ventilation. CIBSE, 2000.

Commissioning Code A: Air distribution systems. CIBSE 1996.

Commissioning Code R: Refrigerating systems. CIBSE 2002.

Commissioning Code W: Water distribution systems. CIBSE 2003.

Guide A: Environmental design. CIBSE, 2006.

Guide B: Heating, ventilating, air conditioning and refrigeration. CIBSE, 2005.

Lighting guide LG2: Hospitals and health care buildings. CIBSE, 2008.

Heating & Ventilating Contractors' Association (HVCA) publications

DW/143: A practical guide to ductwork leakage testing. HVCA Publications, 1998.

DW/144: Specification for sheet metal ductwork, low, medium & high pressure/velocity air systems. HVCA Publications, 1998.

DW/154: Specification for plastics ductwork. HVCA Publications, 2000.

TR/19: Guide to good practice: internal cleanliness of ventilation systems. HVCA Publications, 2005.

Other publications

Advisory committee on Dangerous Pathogens (2001). **The management, design and operation of microbiological containment laboratories.** HSE Books, 2001.

Building Services Research & Information Association (BSRIA). **Application Guide AG 3/89.3: Commissioning of air systems in buildings.** BSRIA, 2001.

Building Services Research & Information Association (BSRIA). **COMPAK 1: Commissioning guides set.**

DIN 1946-4. Ventilation and air conditioning – ventilation in hospitals. Deutsches Institut Fur Normung, 1999.

Health & Safety Commission (2000). **Approved Code of Practice, Legionnaires' disease: the control of legionella bacteria in water systems (L8).** Health and Safety Executive, 2000.

Health & Safety Executive (1993). **HS(G)37: an introduction to local exhaust ventilation.** HSE Books, 1993.

Health & Safety Executive (2005). **Workplace exposure limits: containing the list of workplace exposure limits for use with the Control of Substances Hazardous to Health Regulations 2002 (as amended).** HSE Books, 2005.

Health & Safety Commission's Health Services Advisory Committee (2003). **Safe working and the prevention of infection in clinical laboratories and similar facilities.** HSE Books, 2003.

Health & Safety Commission's Health Services Advisory Committee (2003). **Safe working and the prevention of infection in the mortuary and post-mortem room.** HSE Books, 2003.

Hospital Infection Society (2005). **Microbiological commissioning and monitoring of operating theatre suites.** HIS, 2005.
www.his.org.uk/_db/_documents/OTIC-final.pdf

Medicines and Healthcare products Regulatory Agency (2007). **Rules and guidance for pharmaceutical manufacturers and distributors (The Orange Guide).** Pharmaceutical Press, 2007. www.mhra.gov.uk

Water Regulations Advisory Scheme (WRAS) (2005). **Water Fittings and Materials Directory.** WRAS, 2005. www.wras.co.uk

Whyte W, Lidwell OM, Lowbury EJJ and Blowers R (1983), **Suggested bacteriological standards for air in ultraclean operating rooms.** *J Hosp Infect*, Vol 4, pp 133-139.

Whyte W, Shaw BH and Freeman MAR (1974), **An evaluation of a partial-walled laminar flow operating room.** *J Hyg Camb*, Vol 73, pp 61-75.